

ADVR-07AF

Generator Automatic Voltage Regulator User Manual



Analog / Digital, Single-phase sensing, Excitation Current 7 Amp (Full Wave) / 5Amp (Half Wave), Selectable Full-wave or Half-wave Rectifier Output
For use with self-excited generators.



KUTAI ELECTRONICS INDUSTRY CO., LTD.

TEL : +886-7-8121771

FAX : +886-7-8121775

Website : www.kutai.com.tw

Headquarters : No.3, Lane 201, Chien Fu St., Chyan Jenn Dist., Kaohsiung 80664, TAIWAN



SECTION 1 : SPECIFICATION

Sensing & Power Supply Voltage (AC1, AC2)

Average Readings

Voltage 60 – 300 Vac Single-phase
Select with DIP switch

Adjustment Range
90 – 135 Vac @ 110 Vac
175 – 270 Vac @ 220 Vac

Frequency 50/60 Hz (Select with DIP switch)

External Voltage Adjustment (EXT.VR)

Max. +/- 10% @ 1 K Ω 1 watt potentiometer

Build-up Voltage

Residual voltage at AVR terminal > 5 Vac @ 25 Hz

Soft Start Voltage Build-up Ramp Time

3 seconds +/- 10%

Voltage Regulation Rate

Less than +/- 0.5% (with 4% engine governing)

Response Time

Less than 20 ms

EMI

Built-in electromagnetic interference filter

Static Power Dissipation

Max. 4 watts

Under Frequency Protection (Factory Presets)

50 Hz system presets knee point at 45 Hz
60 Hz system presets knee point at 55 Hz

Voltage Thermal Drift

Less than 3% at temperature range -40 to +70 °C

Under-Frequency Knee Point Thermal Drift

Less than +/- 0.1 Hz at -40 to +70 °C

Operating Environment

Operating Temperature -40 to +70 °C
Storage Temperature -40 to +85 °C
Relative Humidity less than 95%
Vibration 5.5Gs @ 60 Hz

Dimensions

162.0 (L) x 118.5 (W) x 45 (H) mm
6.38 (L) x 4.67 (W) x 1.77 (H) inch

Weight

710 g +/- 2%
1.57 lb +/- 2%

Excitation Output, Resistance and DIP SW Setting

	Input Voltage	DIP SW1	DIP SW2	Excitation Output *1	Exciter resistance	O/E Voltage Protection *2
Half Wave	110 Vac	OFF	ON	Continuous 31 Vdc 5A Max. 45 Vdc 7A 10 Sec	Min.7 Ohm, Max.100 Ohm	Excitation Voltage 35V +/-10 %
	220 Vac	ON	ON	Continuous 63 Vdc 5A Max. 90 Vdc 7A 10 Sec	Min.13 Ohm, Max.100 Ohm	Excitation Voltage 70V +/-10 %
Full Wave	110 Vac	OFF	OFF	Continuous 63 Vdc 7A Max. 90 Vdc 10A 10 Sec	Max.9 Ohm, Max.100 Ohm	Excitation Voltage 70V +/-10 %
	220 Vac	ON	OFF	Continuous 125 Vdc 7A Max. 180 Vdc 10A 10 Sec	Min.18 Ohm, Max.100 Ohm	Excitation Voltage 140V +/-10 %

*1 Fuse specification 5x20mm 8A slow blow.

*2 Over Excitation (O/E) output will decrease after a 10 second delay. This function can be turned OFF

SECTION 2 : EXTERNAL APPEARANCE / DIMENSIONS / INSTALLATION DRAWING

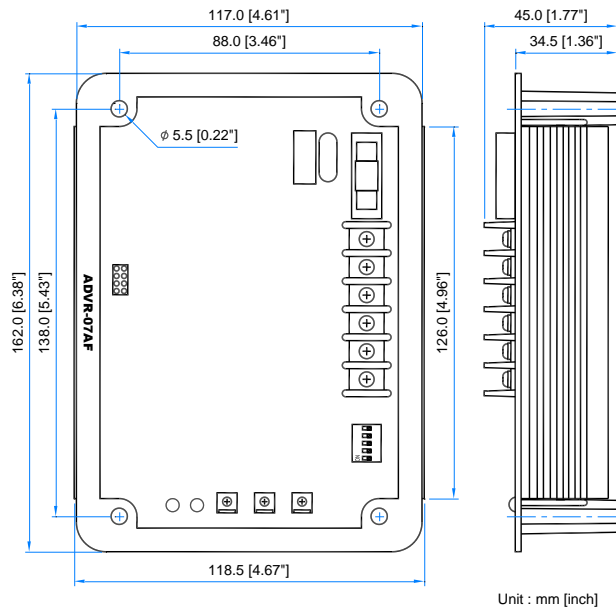

Figure 1 Dimension Drawing

SECTION 3 : LAYOUT DESCRIPTION AND SETTINGS

O/E : Over Excitation Voltage Protection

Turns ON when excitation voltage exceeds Over Excitation Protection setting. Excitation output will decrease if continues for more than 10 seconds.

U/F : Under Frequency Protection LED

Turns ON when Under Frequency activated.

UFRO : Under Frequency Roll Off Protection

50/60 Hz select via DIP SW 3

STAB : Stability Adjustment

Generator response time select via DIP SW 5. In general, larger generators respond more slowly.

VOLT : Voltage Adjustment

110V/220V system select via DIP SW 1.

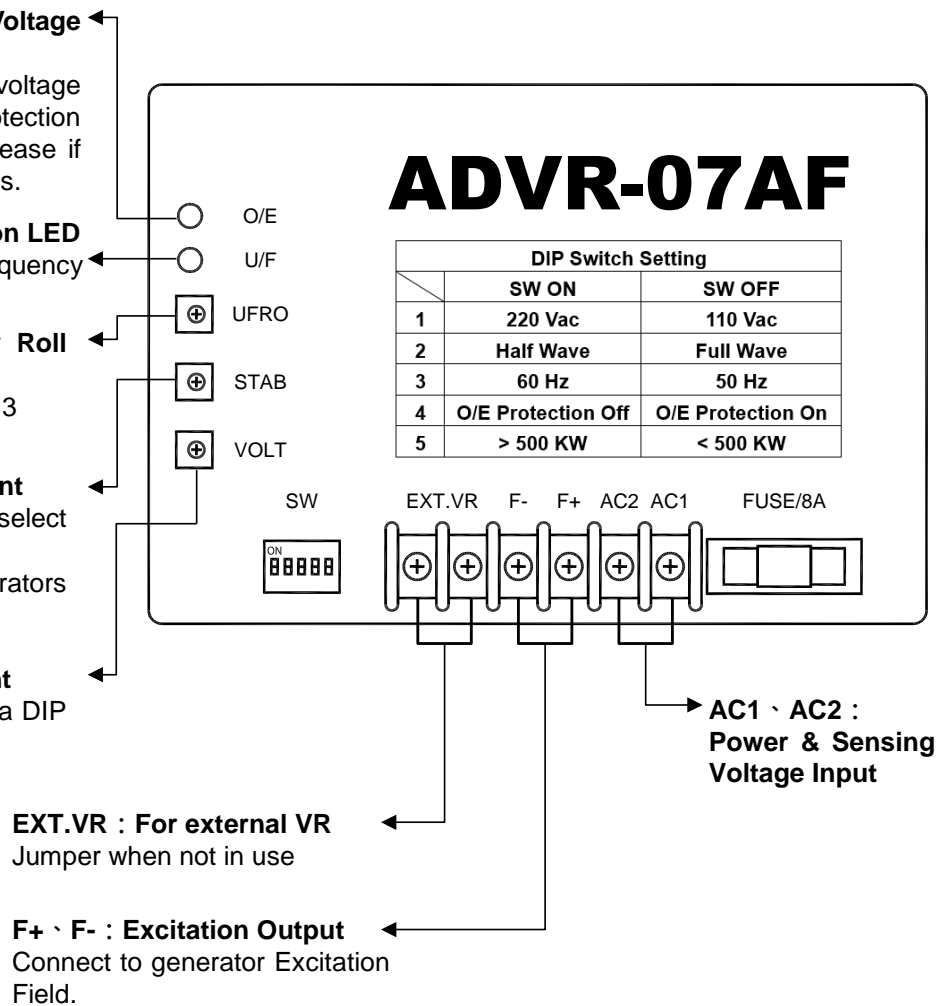

SECTION 4 : CONNECTION DIAGRAM

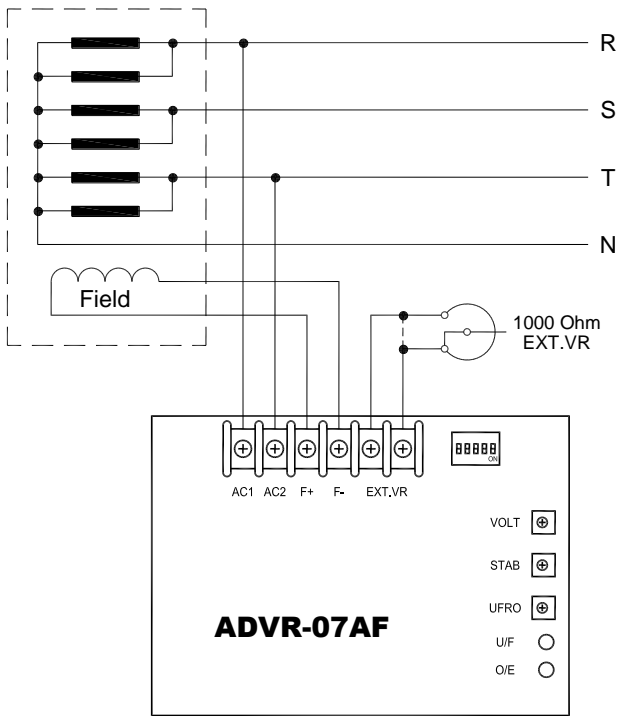

Figure 3 110/220 Vac

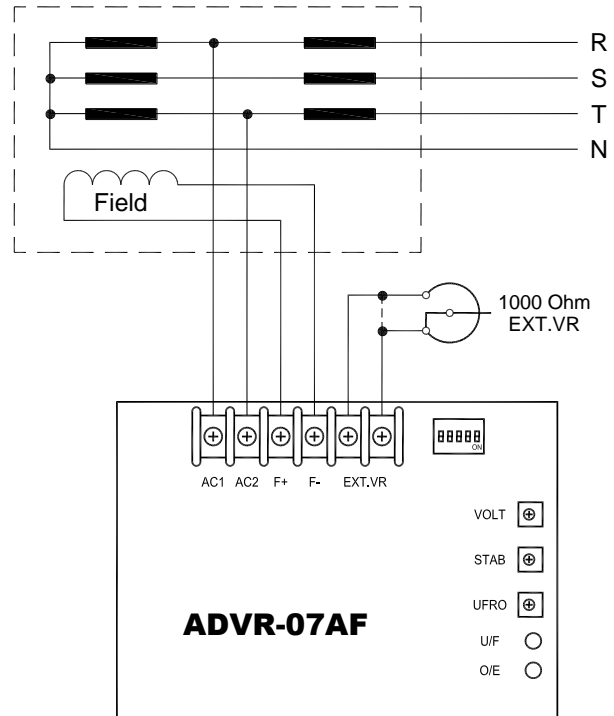

Figure 4 220/380/440 Vac

ATTENTION

1. All voltage readings are to be taken with an average-reading voltmeter Meggers and high-potential test equipment must not be used. Use of such equipment could damage the AVR.
2. Improper setting of under-frequency protection could cause the output voltage of the unit to drop or become unstable under with changes in load. Avoid making any changes to the U/F setting unless necessary.

- ※ Use only the replacement fuses specified in this user manual.
- ※ Appearance and specifications of products are subject to change for improvement without prior notice.