

# GCU-20

## Automatic Engine Control Unit

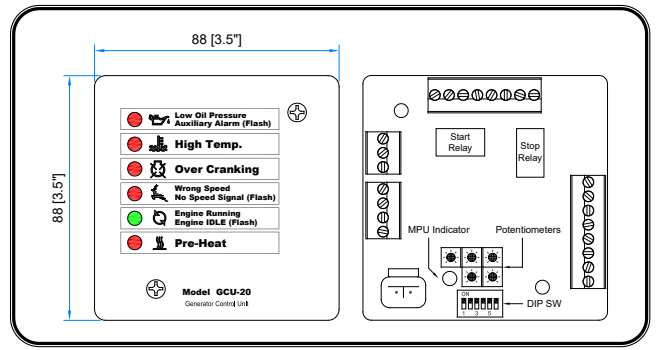

### Physical Dimensions



### Mounting Pattern

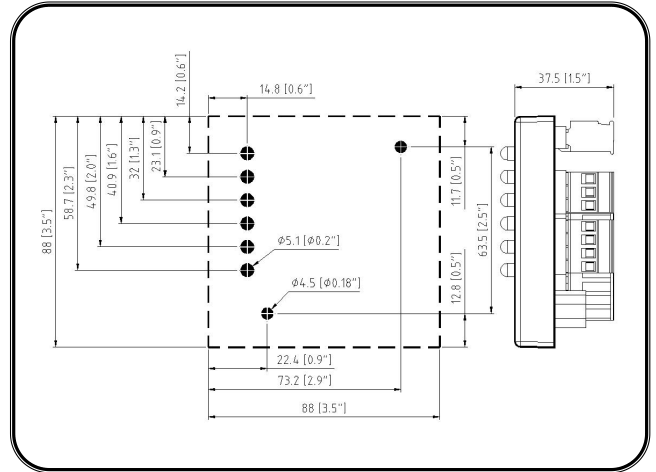

### Installing Panel

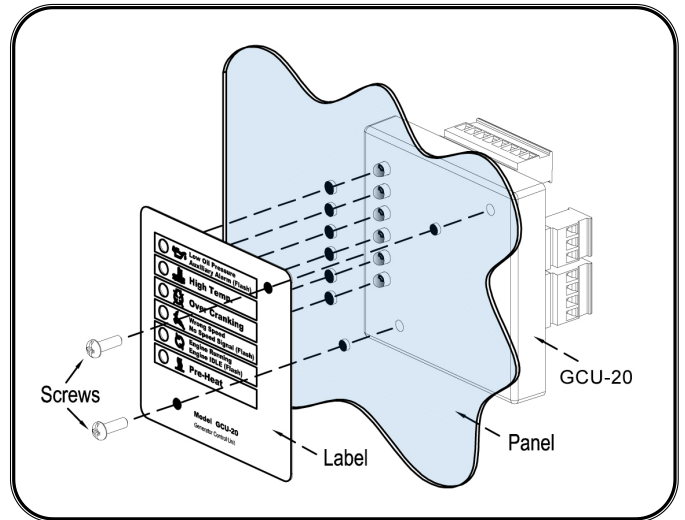

### WARNING

Disconnect all electric power to the machine before installation.

### Protection Functions

#### Engine fail to start

Engine tries 3 times to start

#### Engine Low Oil Pressure Protection

Shutdown activated after 3 seconds  
Oil Pressure Switch Type NO or NC

#### Auxiliary Shutdown

Shutdown activated after 3 seconds delay by NO contact

#### Engine High Coolant Temperature Protection

Shutdown activated after 3 seconds delay by NO contact

#### Engine Over-speed Protection

Shutdown activated after 3 seconds  
50 Hz activated at 55 Hz – 60 Hz activated at 66 Hz

#### Engine Under-Speed Protection

Shutdown activated after 5 seconds  
50 Hz activated at 45 Hz – 60 Hz activated at 54 Hz

#### No Speed Signal Present Protection

Shutdown activated after 5 seconds (MPU use only)

### Icon Reference Table

ICON	DESCRIPTION	ACTION
	Low Oil Pressure Alarm Auxiliary Alarm (Flashing)	Shutdown
	High Coolant Temperature Alarm	Shutdown
	Over Crank Alarm	Shutdown
	Wrong speed Alarm No Speed Signal Alarm (Flashing)	Shutdown
	Engine Running Indicator Engine IDLE Indicator (Flashing)	
	Engine Pre-Heat Indicator	Pre-Heat

## Potentiometers & DIP Switches Detail

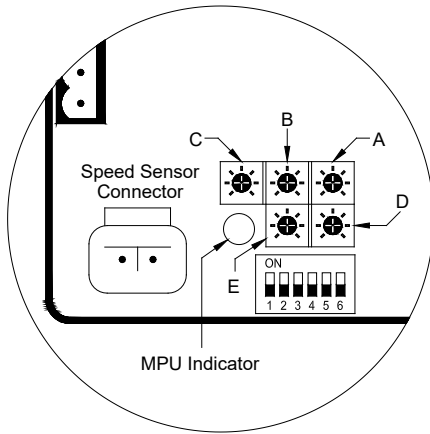

### Adjustments

On the back of the GCU-20 we have five adjustment pots that modify time delay functions.

- **A : Engine Pre-Heat** [Adjustable from 2 to 30 sec]
- **B : Energized to STOP** [Adjustable from 1 to 15 sec]
- **C : Engine Cool-down** [Adjustable from 0 to 300 sec]
- **D : Starter Cranking time** [Adjustable from 1 to 15 sec]
- **E : Engine Idle (Governor)** [Adjustable from 0 to 300 sec]

### Function Setting

Also In the back, the GCU-20 we have six dip / switches that set specific working parameters.

#### SW 1 : Oil Pressure Switch Used for Crank Disconnect

ON - Disable      OFF - Enable

#### SW 2 : Oil Pressure Switch Type

ON - Normal Open      OFF - Normally Close

#### SW 3 : Engine Stop Setting

ON - Energize to Start      OFF - Energize to STOP

#### SW 4 : Generator Frequency (Ignore if it is a Water Pump)

ON - 50 Hz      OFF - 60 Hz

#### SW 5 : MPU Setting

ON - Enable (used to Program Speed)  
OFF - Disable

#### SW 6 : Speed Signal Type

ON - Use MPU for speed sensing  
OFF - Use AC generator frequency for speed sensing

### Lamp Test Function

Applying battery (+) signal to terminal 1 (Lamp Test Terminal) the GCU-20 turns on all the front panel LEDs and annunciator lamps.

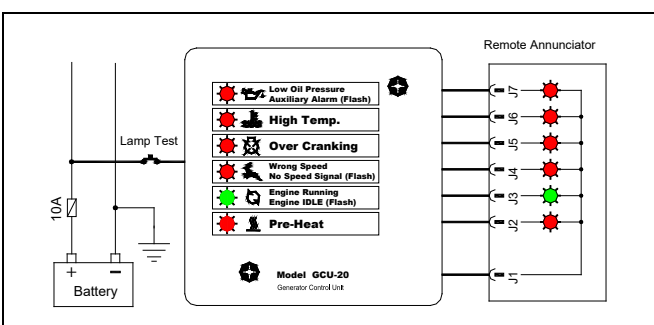

## Using with MPU

If you use the MPU for speed sensing instead of the generator frequency you must set (Switch 6 to ON), and depending on flywheel size (different generators has a different MPU frequencies). This nominal frequency MUST be set FIRST.

It is easy, if you follow the procedure below.

**Step 1 :** Move Switches 5 & 6 to "ON" before starting engine.

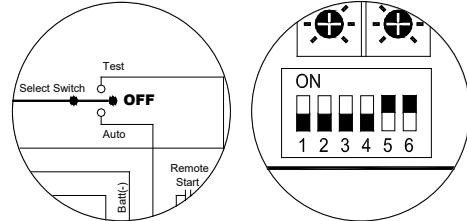

**Step 2 :** Start engine, by moving panel switch to "TEST" (Manual Start)

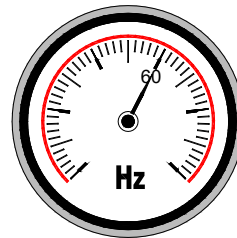
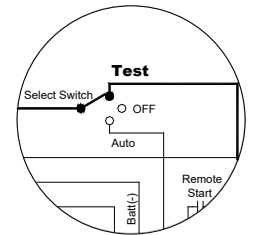

**Step 3 :** Run the engine normally at its rated speed. (60 or 50 Hz) or pump rated RPM

**Step 4 :** Now quickly move Switch 5 to "OFF"

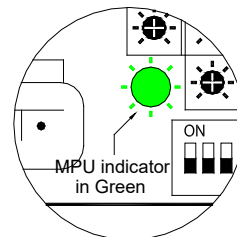
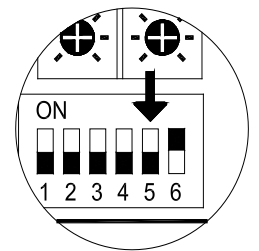

**Step 5 :** When MPU LED turns **GREEN** setup is complete.

### MPU Setup failure

If setup fails, the control module shuts down the engine and immediately flashes ON all the LEDs on the front panel.

Check MPU and wiring before repeating this setup again.

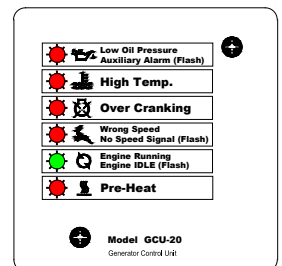

### WARNING

If the MPU signal is used for speed sensing (Switch 6 ON), but MPU frequency set up has not yet been completed the MPU indicator will flash RED and the engine will not run under any condition.

However, if the user tries to start the engine a "No Speed Signal" warning LED will continue to flash indicating that the user should repeat the set up of the MPU frequency setting or switch to generator frequency sensing.

## Specification

ITEM	SPECIFICATION
DC Supply	9 – 36 Vdc
Alternator Input Range	5 – 300 Vac
Alternator Input Frequency	50/60 Hz
MPU Signal Input Range	+/-2V to +/-70 Vac Peak
Rated MPU Frequency	100 – 10,000 Hz
Operating Temperature	-20 to +60 °C
Relative Humidity	Under 90 %
Power Consumption	Under 3W
Weight	206 g +/- 2%

## Terminals Detail

PIN No.	CURRENT MAX.	DESCRIPTION
1	10mA	Auxiliary switch input
2	10mA	Temperature switch input
3	10mA	Oil switch input
4	10mA	Lamp test input
5	10A	Start signal output
6	10A	Battery negative input
7	10mA	AUTO switch input
8 – 9	10mA	Remote start signal input
10	10mA	Test switch input
11	10A	Fuel / Stop signal output
12	300mA	Pre-heat signal output
13 – 18	300mA	Annunciator signal output
19	300mA	Warm-up signal output
20	1A	Annunciator common used only <b>Don't use as main ground connection</b>
21	1A	Accessory ON signal output
22	1A	IDLE control output
23	10A	Battery positive input

## TEST Operation

To initiate a start sequence moves the external toggle switch to the on TEST (Manual Start) position.

**First**, the pre-heat timer begins by energizing terminal 12. If Pre-Heat is not used, simply do not use this terminal.

**Second**, the Engine Fuel Solenoid energizes terminal 11, and idle terminals 22.

**Third**, after a 1 sec. delay, the starter motor energizes, and the engine cranks for the duration of the crank timer.

**Fourth**, after the engine (start / fires), the starter motor disengages and locks out by using the 18-Hertz signal from the generator or the signal from the MPU. Alternatively, the oil pressure switch can serve as an additional back up crank disconnect.

**Fifth**, after the engine fires and if the Engine Idle option is used, the ENGINE RUNNING LED will flash continuously in idle indicating the status is IDLE. (If engine idle is not used - set adjustment, "E" full counterclockwise).

**Sixth**, if the engine does not start the first time the module will try again to start the engine 2 more times and stop after the third try.

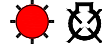

If the generator fails to start, move the select switch to the OFF (Reset) position. Find out why the engine failed to start before making any more start attempts.

**Seven**, after the generator starts, the module allows Oil Pressure, Engine Temperature and engine speed to stabilize without triggering any faults for 20 seconds.

Moving the toggle switch to the OFF position, stops the engine immediately.

## Automatic (Remote Start) Operation

In the "AUTO" mode, the GCU-20 control module monitors input terminals 8 & 9 for a "REMOTE START" signal. Should a "REMOTE START" signal be detected a start sequence similar to previous manual start cycle is initiated.

Removing the Remote Start signal automatically activates the Cool Down Timer and after the Cool Down ends, the Fuel Solenoid is (de-energized or energized as the case may be) bringing the generator or engine to a complete stop.

Should the Remote start signal be re-activated during the cooling down period, the set will immediately return to normal operation.

### NOTE

Even if the generator is executing Engine Cool down Timer, The Module protection system remains in operation and if any failure occurs, the module bypasses the Engine Cooling Timer shutting down the generator immediately.

## OFF Operation

The OFF position places the module into its Stop or Reset mode.

In RESET mode the operator must clear any fault conditions.

Selecting OFF when the engine is running automatically STOPS the generator. The fuel supply will be removed and the engine will be brought to a standstill. Should a remote start signal be present while operating in this mode, a remote start will not occur.

## Wiring Diagram Using Generator AC Frequency Sensing

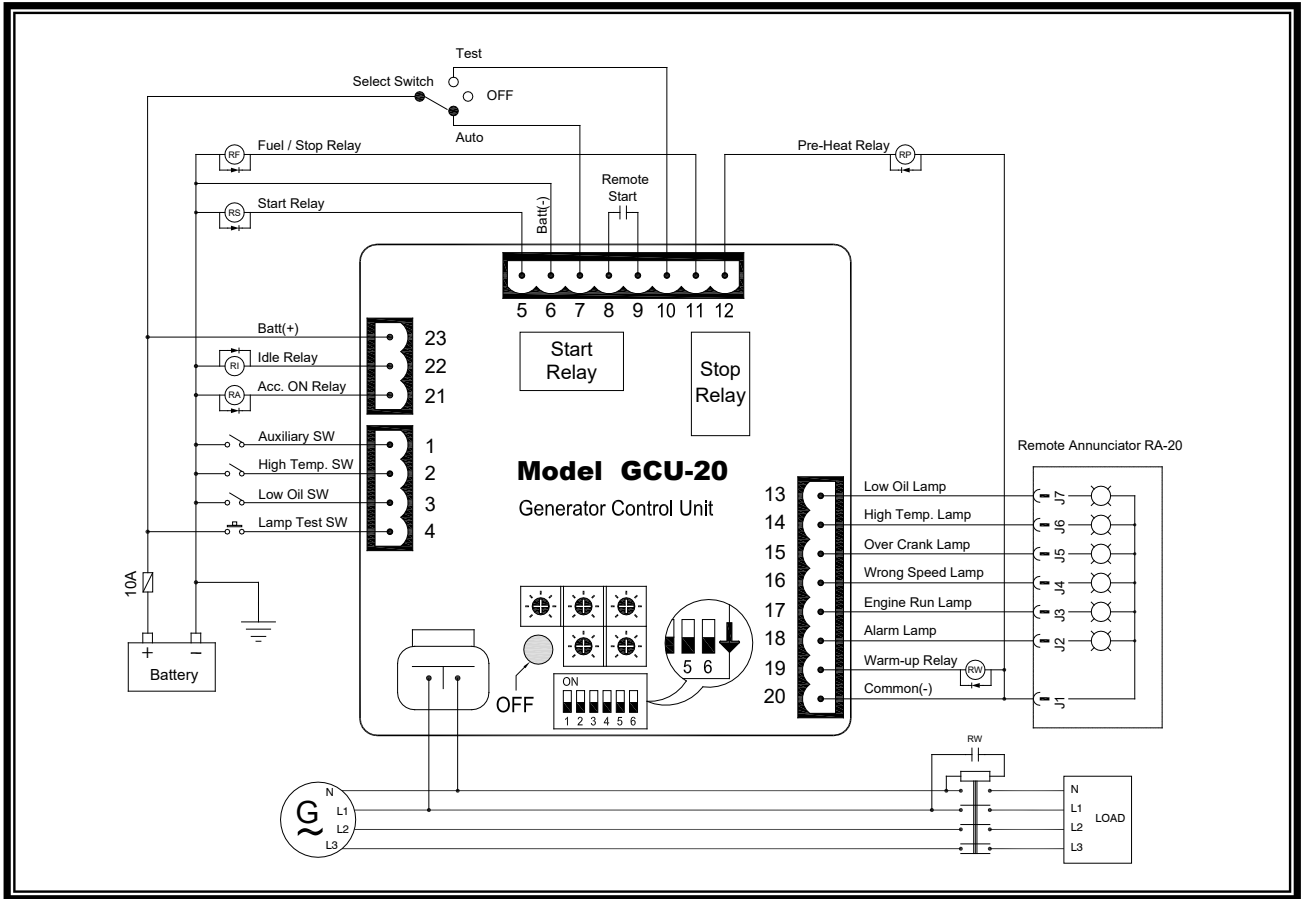

## Wiring Diagram Using MPU Frequency Sensing

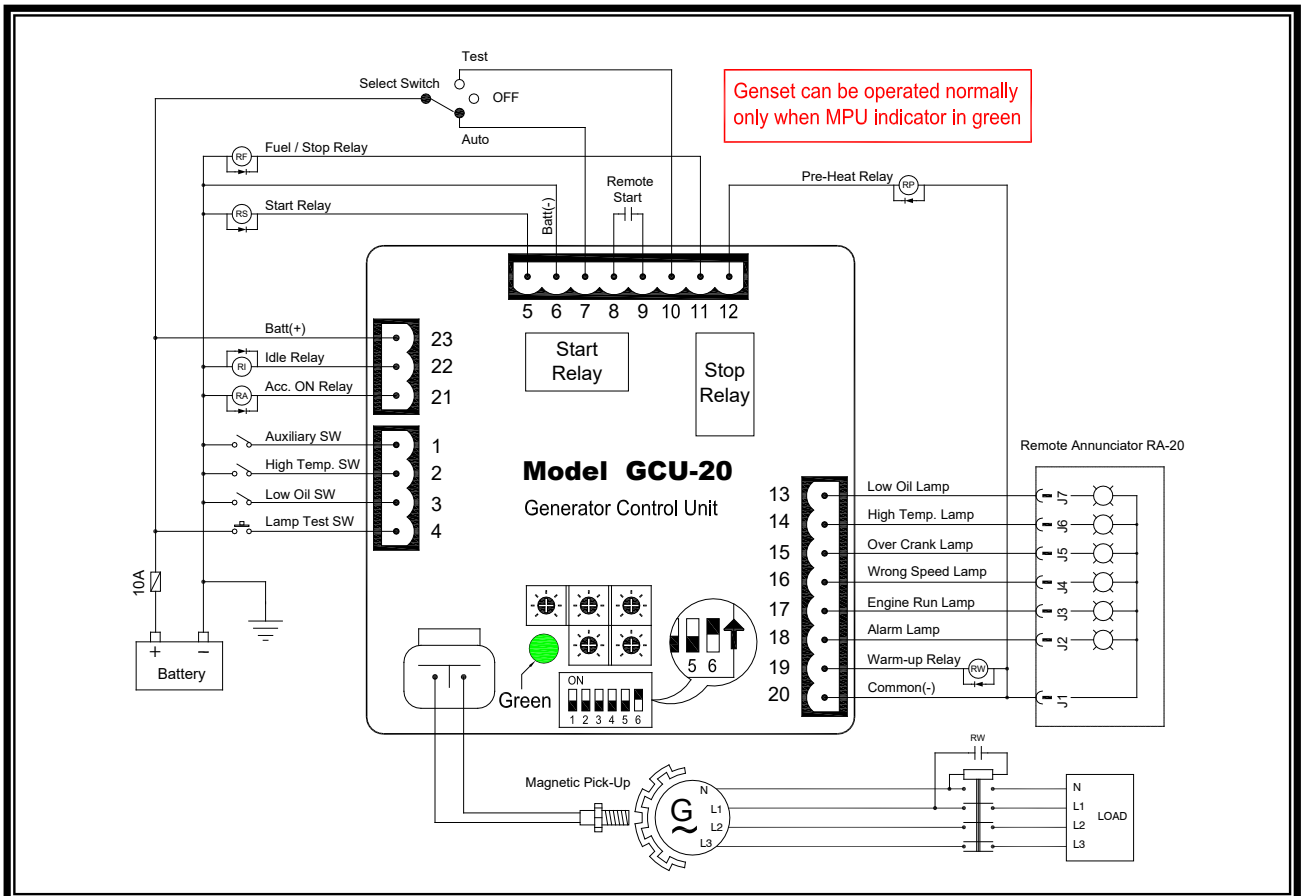

Please link to <http://www.kutai.com.tw> for detailed manual