

ATS-380 Ver1.0

AUTOMATIC TRANSFER SWITCH CONTROL UNIT OPERATOR'S MANUAL

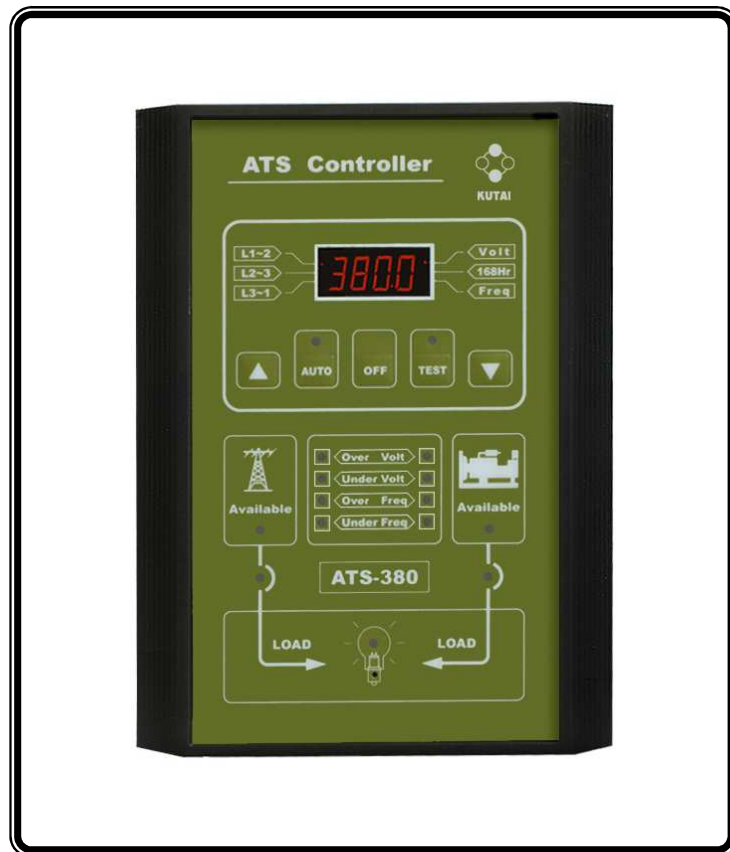

固也泰電子工業有限公司
KUTAI ELECTRONICS INDUSTRY CO., LTD.



Headquarters : No.3, Lane 201, Chien Fu ST., Chyan Jenn Dist., Kaohsiung, TAIWAN

Tel : + 886-7-8121771

Fax : + 886-7-8121775

URL : <http://www.kutai.com.tw>

TABLE OF CONTENTS

<i>Section</i>	<i>Page</i>
SECTOIN 1 : INTRODUCTION	
1.1 Preliminary Comments and Safety Precautions	3
1.2 Background	3
1.3 Product Overview	3
1.4 Functions / Features	4
SECTOIN 2 : HARDWARE DESCRIPTION	
2.1 General.....	6
2.2 Display Window.....	6
2.3 Operate Pushbuttons	6
2.4 Panel LEDs Outputs	6
2.5 Rear Access Area	6
SECTOIN 3 : OPERATOR PANEL	
3.1 General.....	9
3.2 Display Window.....	9
3.3 Operate Pushbuttons	9
3.4 Panel LED Outputs	9
SECTOIN 4 : OPERATION	
4.1 General.....	10
4.2 Automatic Mode	10
4.3 Engine Test Mode	11
4.4 Off Mode	11
4.5 Programming Mode.....	11
4.6 Specification Summary	13
SECTOIN 5 : INSTALLATION INSTRUCTIONS	
5.1 General.....	13
5.2 Panel Cut-Out	13
5.3 Unit Dimensions	14
SECTOIN 6 : TYPICAL WIRING	
6.1 General.....	14
6.2 3Phase 3Wire Connecting Wire Diagram	15
6.3 1Phase 3Wire Connecting Wire Diagram	19
6.4 Single Phase Connecting Wire Diagram.....	23
6.5 Connecting Wire Diagram When The Transfer Current Over 6 Amps	27

SECTION 1 : INTRODUCTION

1.1 Preliminary Comments and Safety Precautions

This technical document is intended to cover most aspects associated with the installation, application, operation and maintenance of the ATS-380 Automatic Transfer Switch Controller. It is provided as a guide for authorized and qualified personnel application of the ATS-380 Automatic Transfer Switch Controller.

1.2 Background

Transfer switches are used to protect critical electrical loads against loss of power. The load's normal power source is backed up by a standby (emergency) power source. A transfer switch is connected to both the normal and emergency sources and supplies the load with power from one of these two sources. In the event that power is lost from the normal source, the transfer switch transfers the load to the standby source. Once normal power is restored, the load was transferred back to the normal power source.

When using the ATS-380 module in automatic transfer switch equipment, the switch's intelligence system initiates the transfer when normal power falls below or over a preset voltage or frequency. If the emergency source is a standby generator, the transfer switch initiates generator starting and transfers to the standby source when sufficient generator voltage and frequency is available. When normal power is restored, the transfer switch automatically transfers back and initiates engine shutdown after a preset engine cooling down time delay.

An automatic transfer switch consists of three basic elements:

1. Main contacts to connect and disconnect the load to the source of power.
2. A transfer mechanism to affect the transfer of the main contacts from one source to another source.

3. Intelligence control unit to constantly monitor the condition of the power sources and thus provide the intelligence necessary for the switch and related circuit operation.

This manual deals with the third basic element of the automatic transfer switch, the required intelligence automatic control module. All the Automatic Transfer Switch functions were performed by a door mounted logic panel ATS-380 control unit. The ATS-380 logic panel brings intelligence, supervisory and programmable capabilities to automatic transfer switch equipment.

1.3 Products Overview

The ATS-380 Automatic Transfer Switch control module is an intelligence, comprehensive, multi-function, microprocessor based automatic transfer switch controller. It is a compact panel mounted device designed to replace traditional relay and solid state logic panels and meet the needs of markets worldwide.

The ATS-380 controller provides an unmatched degree of programmed flexibility to address the needs of most switches system. It can be programmed for 3 \emptyset and 1 \emptyset system operation. (Refer to program line 2.)

The ATS-380 controller provides the necessary intelligence to insure that the switch operates properly through a series of programmed sensing and timing functions. The ATS-380 controller will :

- Monitor Normal and Standby source over and under voltages.
- Monitor Normal and Standby source over and under frequencies.
- Permit customer programming display real time information.
- Permit customer programming cyclic mode or fix mode display for 3 phase voltages and frequency. (Refer to program line 29.)
- Permit system testing the transfer switch with/without load from front panel. (Refer to program line 4.)
- Store customer / factory established parameters in memory without losing.

- Built-in one week exerciser timer.
- Permit customer plant engine test with / without load on a preset period.
- Provide programmable per-exerciser warming signal.
- Provide a pre-transfer signal to elevator controller before transfer switch.
- Provide programmable alarm output when transfer failure.
- There is no need for a PC connection and programming software. Any and all changes can be made in the field.
- Provide the source status and fail alarm indications on the front panel.

1.4 Functions / Features

The primary function of ATS-380 controller is to accurately monitor power sources and provide the necessary intelligence to operate a transfer switch in an appropriate and timely manner.

1.4.1 Operational Simplicity

From installation to programming to usage, the ATS-380 controller was designed with operational simplicity in mind. The ATS-380 controller operates with system voltage from 280 VAC to 480 VAC at 50 or 60 Hz. The user-friendly front panel interface simplifies routine operation, programming and setting adjustments.

1.4.2 Standard Features

A variety of programmable features are available to meet a wide variety of application requirements. Individual features or feature combinations provide the Intelligence required tailoring switches to individual needs. The features can be programmed by customer via friendly setting procedure, depending upon customer requirements. The specific variable set points associated with standard and factory activated features are stored in a nonvolatile memory. Activated feature set points are available for customer adjustment.

Feature 1 : Time Delay Normal to Emergency (TDNE)

TDNE provides a time delay when transferring the Normal source to the Standby source. It ensures stability of the Standby source. Timing begins when the Standby Source becomes available. (Refer to program line 6.)

Adjustable TDNE range : 0 ~ 60 (0 ~ 300 sec)

Feature 2 : Time Delay Engine Start (TDES)

TDES delays the initiation of the engine start circuit in order to override momentary power outages or voltage fluctuations of the Normal source. The TDES timer shall start when the Normal source becomes unavailable. If the Normal source becomes available while timing, the TDES timer will reset. The ATS-380 controller can perform the time delay engine start function without control power for 30 seconds. (Refer to program line 7.)

Adjustable TDES range : 0 ~ 6 (0 ~ 30 sec)

Feature 3 : Time Delay Emergency to Normal (TDEN)

TDEN delays the transfer from the Standby source to the Normal Source to permit stabilization of the Normal Source before retransfer is made. Timing begins when the Normal Source becomes available. (Refer to program line 5.)

Adjustable TDEN range : 0 ~ 60 (0 ~ 300 sec)

Feature 4 : Time Delay Engine Cool-down (TDEC)

TDEC permits the generator to continue to run unloaded after retransfer to the Normal Source has occurred. Timing begins when the transfer to normal has been completed. (Refer to program line 8.)

Adjustable TDEC range : 0 ~ 60 (0 ~ 300 sec)

Feature 5 : All Phase Under / Over voltage Sensing

The controller monitors the voltage of each phase of the normal and standby power source. User adjustable settings are provided. (Refer to program line 9,10,11,15,16 & 17.)

Adjustable Over voltage range: 390VAC ~ 480VAC

Adjustable Under voltage range: 280VAC ~ 370VAC

Feature 6 : Under/Over frequency Sensing

The controller monitors the frequency of the normal and standby power source. User adjustable settings are provided. (Refer to program line 12,13,14,18,19 & 20.)

Adjustable Over frequency range : 51Hz ~ 70Hz

Adjustable Under frequency range : 40Hz ~ 59Hz

Feature 7 : Plant Exerciser

This feature provides for automatic test operation of the generator. The interval is fixed at once per week with a specific test day and time. The test period is also programmable by customer setting. The ATS-380 control unit permit customer plant engine test with / without load on a preset period. (Refer to program line 21,22,23,25,26,27 & 28.)

Feature 8 : Pre-transfer Signal Output

When the auxiliary contactor was set to be a pre-transfer signal output. The ATS-380 controller will provide a pre-transfer signal to elevator controller before transfer the load from one source to another source with a preset time delay. The pre-transfer return to normal state after the transfer is complete. (Refer to program line 30 & 31.)

Adjustable range : 1 ~ 99 sec.

Feature 9 : Pre-exerciser Signal Output

When the auxiliary contactor was set to be a pre-exerciser signal output. The ATS-380 controller will provide a pre-transfer signal output before exerciser the engine. It is an advance warning to avoid person damaged before the generator auto start itself. (Refer to program line 30 & 32.)

Adjustable range : 1 ~ 99 sec.

Feature 10 : Transfer Fail Alarm Signal Output

When the auxiliary contactor was set to be a transfer fail alarm output. The auxiliary contactor may be wired to an alarm enunciator panel to indicate problem with the Automatic Transfer Switch.

An alarm condition will occur if a transfer has been initiated but it is never completed. This may indicate that something is wrong with the motor or transfer mechanism. (Refer to program line 30)

NOTICE

The ATS-380 controller provided an aux. contactor for external signal output only. So, this contactor just can define to one of the three features used. (Pre-transfer, Pre-exerciser or Transfer fail alarm output.)

Feature 11 : Fail Alarm On Display

FAIL on the front panel of the ATS-380 indicates that a transfer was initiated but never completed. This can point toward a defective motor, transfer mechanism or the wrong programming for line 3. When the transfers fail alarm occurred, the ATS will hold this position until the OFF button is pressed to reset alarm signal.

NOTE! Normally, MCCB type ATS need longer running time to complete there cycle, so if line 3 is set wrong the switch stops before completing it's cycle and the ATS-380 will give you a FAIL transfer Alarm. Make sure the line 3 setting is set right before checking any other parts of the ATS mechanism.

SECTION 2 : HARDWARE DESCRIPTION

2.1 General

The purpose of this section is to familiarize the reader with ATS-380 hardware, its nomenclature, and to list the unit specifications. The information presented is divided into the following parts:

- Front Display Window
- Operate Pushbuttons
- Panel LEDs Outputs
- Rear Access Area

2.2 Display Window (Refer to Figure 1)

A 4 digit 7-segment display is used to display all ATS-380 controller monitored parameters, setting parameters and messages in easy to read formats.

For details concerning the kind of information that can be viewed in the display window refer to Paragraph 3.2.

2.3 Operate Pushbuttons (Refer to Figure 1)

The front operator panel supports five long-life pushbuttons. Pushbuttons accomplish their function when pressed and released. Refer to Paragraph 3.3 for information concerning the function of specific pushbuttons.

2.4 Panel LEDs Outputs (Refer to Figure 1)

Thirteen individual LEDs are lit when performing or indicating a specific function. For detailed information on individual LEDs refer to Paragraph 3.4.

2.5 Rear Access Area (Refer to Figure 2)

The rear access area of the ATS-380 controller is normally accessible from the rear of panel. A wiring connection to the ATS-380 controller is made at the rear of the chassis.

For detailed information of connecting wire diagram refer to Paragraph 6.

Front Panel

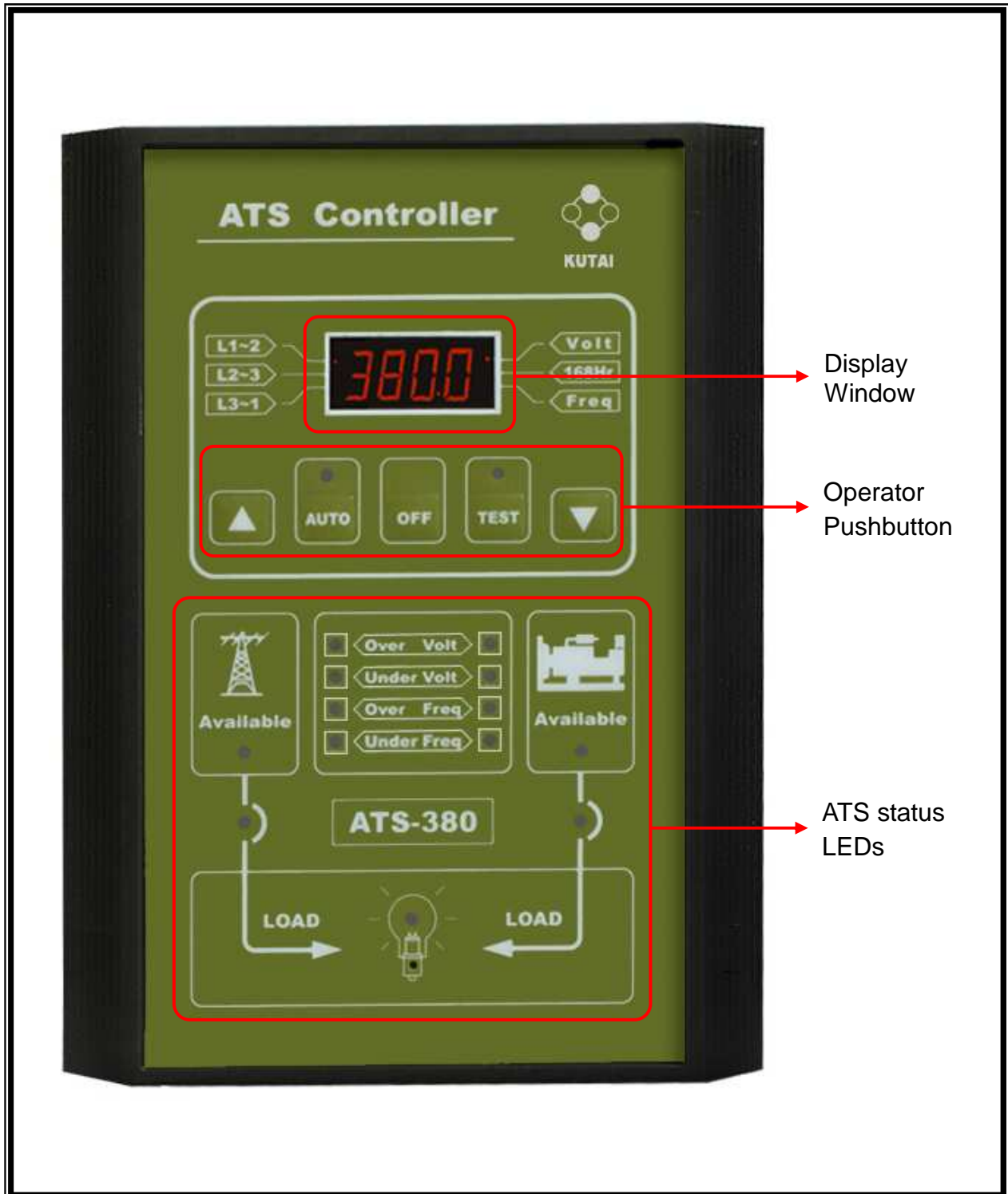

Figure 1

Rear Area

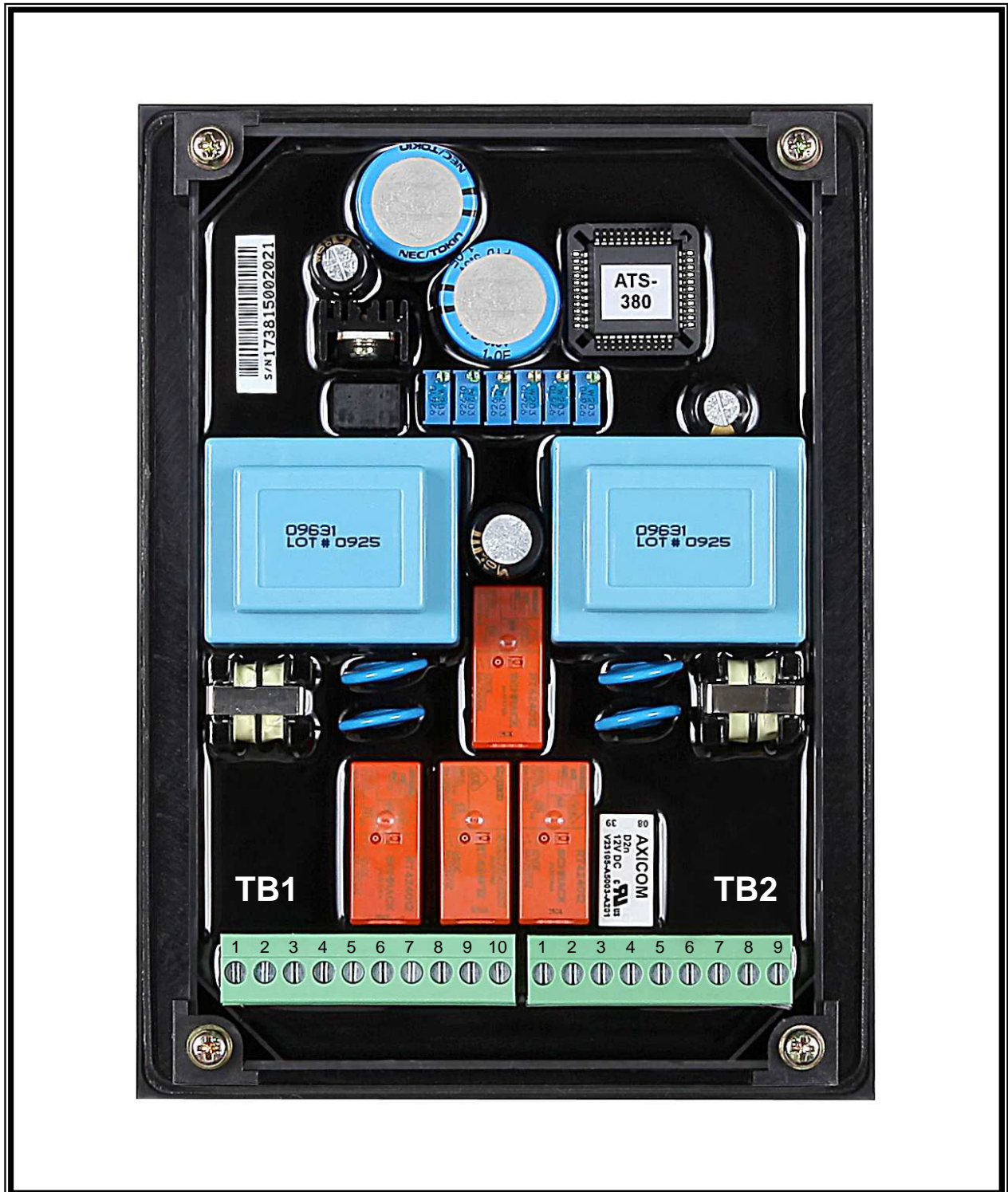

Figure 2

SECTION 3 : OPERATOR PANEL

3.1 General

The operator panel, which is normally accessible from the outside of a panel or door, provides a means for being alerted to specific conditions, receiving functional help, programming and parameter monitoring.

3.2 Display Window

The ATS-380 controller includes a 4 digit 7-segment display is used to display all monitored parameters, setting parameters and messages in easy to read formats.

Different displays can be presented via the display window:

- Normal source voltage and frequency parameter display.
- Standby source voltage and frequency parameter display.
- TDEN,TDNE and TDEC real time countdown display.
- Program setting parameter display.

NOTICE

Although a wide variety of parameters and setting can be displayed, they are not displayed if they were not originally ordered and programmed.

3.3 Operate Pushbuttons

There are five front panel pushbuttons accomplish their function when pressed and released. Certain pushbuttons, like the increase(▲)and decrease(▼) pushbuttons, will also continue to scroll if they are pressed and not released at program procedure.

3.3.1 Increase (▲) Pushbutton

When the ATS-380 controller operated at normal status, each press of the increase (▲) key will change the real parameter display from one phase to another phase. When the user initiates the program mode, each press of the Increase (▲) key

will scroll through all available parameter. When pressing and releasing the increase (▲) button the displayed parameter can be increased by one. The Increase (▲) pushbutton will continue to scroll if it is pressed and not released.

3.3.2 Decrease (▼) Pushbutton

At the normal operate status, each press of the decrease (▼) key will change the real parameter display between voltage and frequency. When the user initiates program mode, each press of the decrease (▼) key will scroll through all available parameter. When pressing and releasing the decrease (▼) button the displayed parameter can be decreased by one. The decrease (▼) pushbutton will continue to scroll if it is pressed and not released.

3.3.3 Auto Function Pushbutton

Pushing the AUTO select key, the ATS-380 will run in automatic mode and a LED is provided to indicate the auto position. The ATS transfer and retransfer from source to source as dictated by the features supplied and their programmed setting values.

3.3.4 Test Function Pushbutton

The ATS-380 is provided with a test pushbutton that simulates a loss of normal source. Pushing the TEST select key, the ATS-380 will run in engine test mode and a LED is provided to indicate the test position.

3.3.5 Off Function Pushbutton

Pushing the OFF select key, the ATS-380 will run in off mode. All the functions of the ATS-380 controller Will be disable.

When in program mode, pushing the off pushbutton allows the user to change the program line table and set the selected parameter using decrease (▼) or increase (▲) button.

3.4 Panel LED Outputs

Auto Position (Green)

Indicates that the ATS-380 controller is setting to AUTO function.

Test Position (Green)

Indicates that the ATS-380 controller is setting to TEST function.

Normal Source Available (Green)

Indicates that the normal source is available and the voltage and frequency are within the programmed parameters.

Normal Source Connected (Green)

Indicates that the transfer switch is connected to the normal source.

Standby Source Available (Green)

Indicates that the standby source is available and the voltage and frequency are within the programmed parameters.

Standby Source Connected (Green)

Indicates that the transfer switch is connected to the standby source.

Load Connected (Green)

Indicates that the load is connected to the normal or standby source.

Normal Over Voltage (Red)

Indicates that the normal source is unavailable and the voltage is over the programmed parameters.

Normal Under Voltage (Red)

Indicates that the normal source is unavailable and the voltage is below the programmed parameters.

Normal Over Frequency (Red)

Indicates that the normal source is unavailable and the frequency is over the programmed parameters.

Normal Under Frequency (Red)

Indicates that the normal source is unavailable and the frequency is below the programmed parameters.

Standby Over Voltage (Red)

Indicates that the standby source is unavailable and the voltage is over the programmed parameters.

Standby Under Voltage (Red)

Indicates that the standby source is unavailable and the voltage is below the programmed parameters.

Standby Over Frequency (Red)

Indicates that the standby source is unavailable and the frequency is over the programmed parameters.

Standby Under Frequency (Red)

Indicates that the standby source is unavailable and the frequency is below the programmed parameters.

SECTION 4 : OPERATION

4.1 General

This section specifically describes the operation and functional use of the ATS-380 controller. It is divided into four main categories:

- Automatic mode
- Engine test mode
- Off mode
- Programming mode

The practical use of and operation within each category will be discussed. In this section it is assumed that prior sections were reviewed and that operator has a basic understanding of the hardware.

4.2 Automatic Mode

The automatic mode of the ATS-380 controller provides for automatic transfer and retransfers from source to source as dictated by the features supplied and their programmed values.

The ATS-380 controller intelligence and supervisory circuits which constantly monitor the condition of both normal and standby power sources thus providing the required intelligence for transfer operations.

For example, automatically initiate an transfer of power when power fails or voltage level drops below a preset value. Exactly what the ATS-380 controller will initiate in response to a given system condition depends upon the combination of standard and selected optional features.

4.3 Engine Test Mode

The ATS-380 is provided with a test pushbutton that simulates a loss of normal source. Pushing the TEST key on the front of panel, the ATS-380 will run in engine test mode. The TDES and TDNE programmed time delays will be performed as part of the Test. There are two test modes:

- With load engine test.
- Without load engine test. (The TDNE time delay will not be performed)

When the user terminated the engine test mode by press the AUTO pushbutton, then the controller will return to automatic mode. When normal power is available, the transfer switch automatically transfers back from standby source to normal source and initiates engine shutdown after a preset engine cooling down time delay.

When the user terminated the engine test mode by press the OFF pushbutton, the ATS will keeps the present status and the ATS-380 controller initiates engine shutdown immediately without cooling down time delay and returns to off mode.

4.4 Off Mode

The off mode of the ATS-380 controller will disable all the transferred and protected functions, and all the status LEDs will be turned off in this mode. The real time clock will be showed on the front display window.

In the event that power is lost from the normal source, the ATS-380 controller will not start the engine and the ATS can't transfer the load to the standby source automatically.

When in program mode, pushing the off pushbutton allows the user to change the program line table and set the selected parameter using decrease (▼) or increase (▲) button.

4.5 Programming Mode

The ATS-380 controller is fully programmable from the devices faceplate once in the Programming Mode. Any operator associated with programming the ATS-380 controller will quickly discover that ATS-380 controller programming is just a matter of simple.

Begin to start programming mode, set the ATS-380 on off mode, push the button " increase (▲) & decrease (▼) " on the front panel for 4 seconds. The word " Ver 1.0 " will appear on the front display window for 2 seconds. This number indicates the version of the software.

You are now ready to start a line by line programming sequence. To advance to the next line, push the OFF button on the front panel. To change each line's programming parameters, press the increase (▲) and decrease (▼) buttons. When pressing and releasing the increase (▲) or decrease (▼) key the displayed parameter can be increased or decreased by one. The Increase (▲) or decrease (▼) pushbutton will continue to scroll if it is pressed and not released.

Always push the " OFF " button to advance to next programming line or until the word " END " appears on the screen. To immediately end the programming mode, you can simply push the " OFF " button for 4 seconds at any time. Then the word " END " on the display window indicates the end of the programming mode.

Should you make an error or desire to return to factory settings, stay in programming mode and simultaneously press all 3 buttons : increase (▲), decrease (▼) and OFF for 4 seconds. The ATS-380 controller will now automatically program itself to factory settings and the word " Au.Po " will appear on the display window. (See line by line programming table for ATS-380 factory settings.)

*** LINE BY LINE PROGRAMMING TABLE**

LINE	DISCRIPTION	VALUE	Factory Setting
1	System voltage setting (250V ~ 500V)	Key in the real volt of normal side R & T	380V
2	Is this ATS operator in 1Ø or 3Ø	1) 1Ø 2) 3Ø	2
3	Selected the Switch type of ATS	1) MCCB type 2) Double throw type 3) Magnetic contactor type	1
4	Plant Manual test with or without load	1) Test without load 2) Test with load	2
5	TDEN – Time delay emergency to normal	0 ~ 60 (0 ~ 300sec)	2 (10sec)
6	TDNE – Time delay normal to emergency	0 ~ 60 (0 ~ 300sec)	2 (10sec)
7	TDES – Time delay engine start	0 ~ 06 (0 ~ 30sec)	1 (5sec)
8	TDEC – Time delay engine cool-down	0 ~ 60 (0 ~ 300sec)	12 (60sec)
9	Normal source over voltage setting	39 ~ 48 (390V ~480V)	42 (420V)
10	Normal source under voltage setting	28 ~ 37 (280V ~ 370V)	34 (340V)
11	Time delay if there is a problem with normal source voltage output	0 ~ 99sec (0 = Without voltage monitor function)	10 Sec
12	Normal source over frequency setting	51 ~ 70Hz	55Hz
13	Normal source under frequency setting	40 ~ 59Hz	45Hz
14	Time delay if there is a problem with normal source frequency output	0 ~ 99sec (0 = Without freq monitor function)	10 Sec
15	Standby source over voltage setting	39 ~ 48 (390V ~480V)	42 (420V)
16	Standby source under voltage setting	28 ~ 37 (280V ~ 370V)	34 (340V)
17	Time delay if there is a problem with standby source voltage output	0 ~ 99sec (0 = Without volt monitor function)	10 Sec
18	Standby source over frequency setting	51 ~ 70Hz	55Hz
19	Standby source under frequency setting	40 ~ 59Hz	45Hz
20	Time delay if there is a problem with standby source frequency output	0 ~ 99sec (0 = Without freq monitor function)	10 Sec
21	Current day of week setting	1 ~ 7 (Mon to Sun)	current
22	Current hour setting	00 ~ 23	current
23	Current minute setting	00 ~ 59	current
24	Plant exerciser test day of week	1 ~ 7 (Mon to Sun)	6(Sat)
25	Plant exerciser hour	00 ~ 23	12
26	Plant exerciser minute	00 ~ 59	00
27	Engine run time on exerciser	0 ~ 60 min (0 = Without exerciser function)	0
28	Plant exerciser test with or without load	1) Without load 2) With load	1
29	Display mode setting	1) Cyclic mode 2) Fix mode	1
30	Auxiliary contactor feature (The contactor just can define to one of the three features)	1) Transfer fail alarm 2) Pre-transfer signal 3) Pre-exerciser signal	2
31	Pre-transfer time delay before transfer load from one source to another source	1 ~ 99 sec	10 Sec
32	Pre-exerciser time delay before engine exerciser test	1 ~ 99 sec	10 Sec

4.6 Specification Summary

PARAMETER	SPECIFICATION
Input Control Voltage	280 VAC to 480 VAC 50/60 Hz
Voltage Measurement Range	280 VAC to 480 VAC 50/60 HZ
Frequency Measurement Range	40HZ to 70HZ
Generator Start Relay	7A @ 250VAC Max
Transfer to Normal Relay	7A @ 250VAC Max
Transfer to Standby Relay	7A @ 250VAC Max
Auxiliary Relay	0.5A @ 120VAC 1.0A @ 24VDC
Operating Temperature	-20°C ~ 70°C
Storage Temperature	-35°C ~ 85°C
Operating Humidity	0 to 95% relative humidity

SECTION 5 : INSTALLATION INSTRUCTIONS

5.1 General

The ATS-380 controller has been designed for front panel mounting.

5.2 Panel Cut-Out (All Dimensions in MM.)

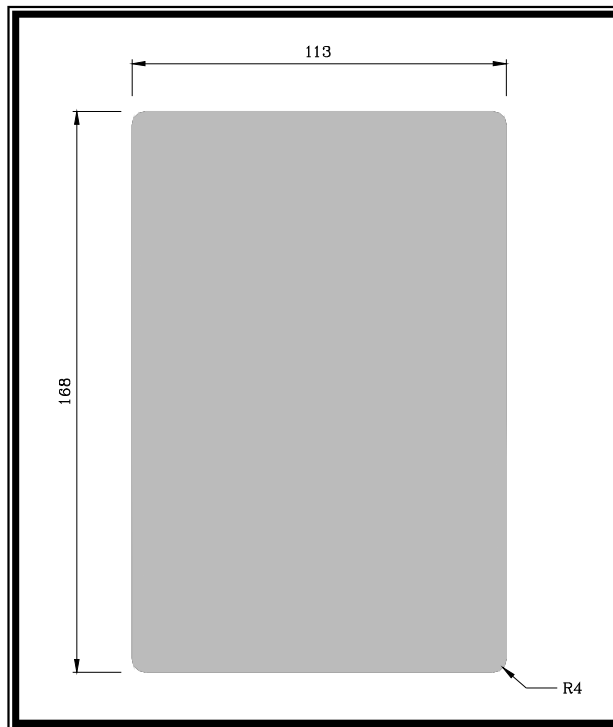

5.3 Unit Dimensions (All Dimensions in MM.)

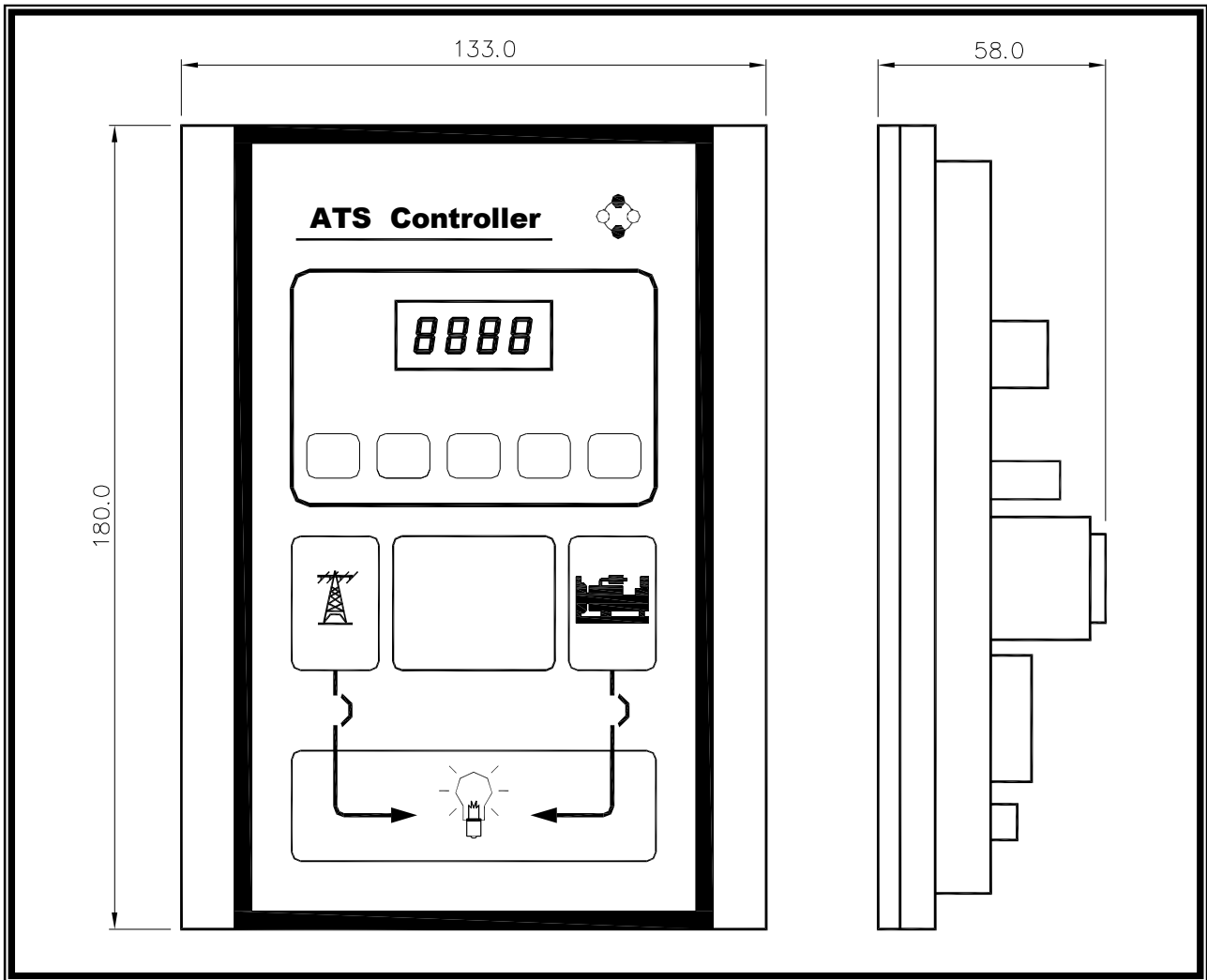

SECTION 6 : TYPICAL WIRING

6.1 General

It is dangerous to feed high voltage to the ATS-380 Printed Circuit boards. The ATS-380 controller operates with system voltage from 280 VAC to 480 VAC at 50 or 60 Hz.

The ATS-380 allowed User to adjust the display voltage by key in the real voltage value of normal source L1 ~ L3. The ATS-380 controller will follow the scale between input volt and key in volt and show the correct voltage on the display window. (refer to program line 1)

The ATS-380 maximum transfer current is 6 Amps. When the switch transfer current over 6 Amps, two external power relays is recommended. (The connecting wire diagram refer to 6.5 section.)

6.2 4P 380V Connecting Wire Diagram

6.2.1 MCCB Type Wiring Diagram

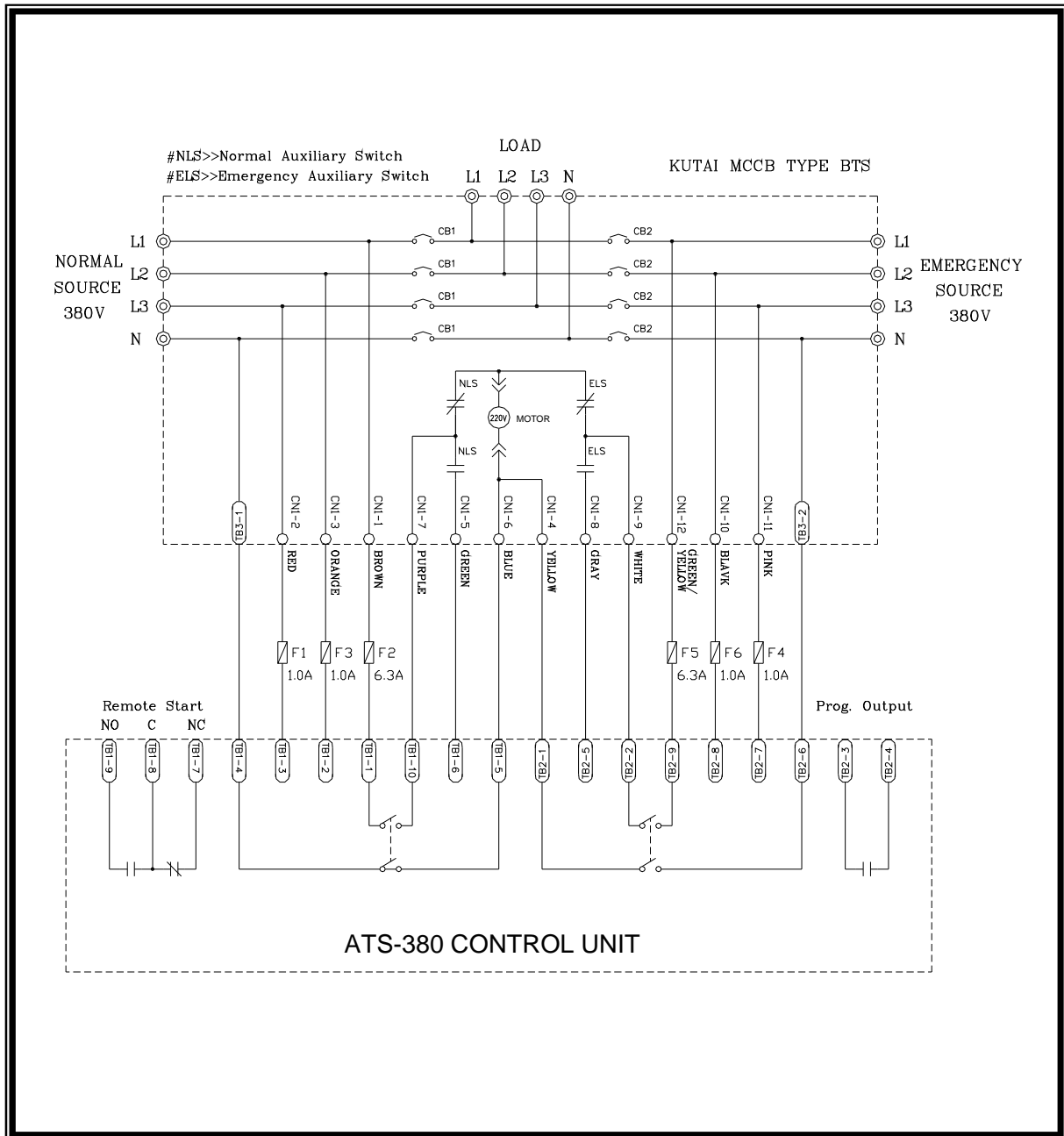

6.2.2 One Coil Double Throw Typical Wiring Diagram

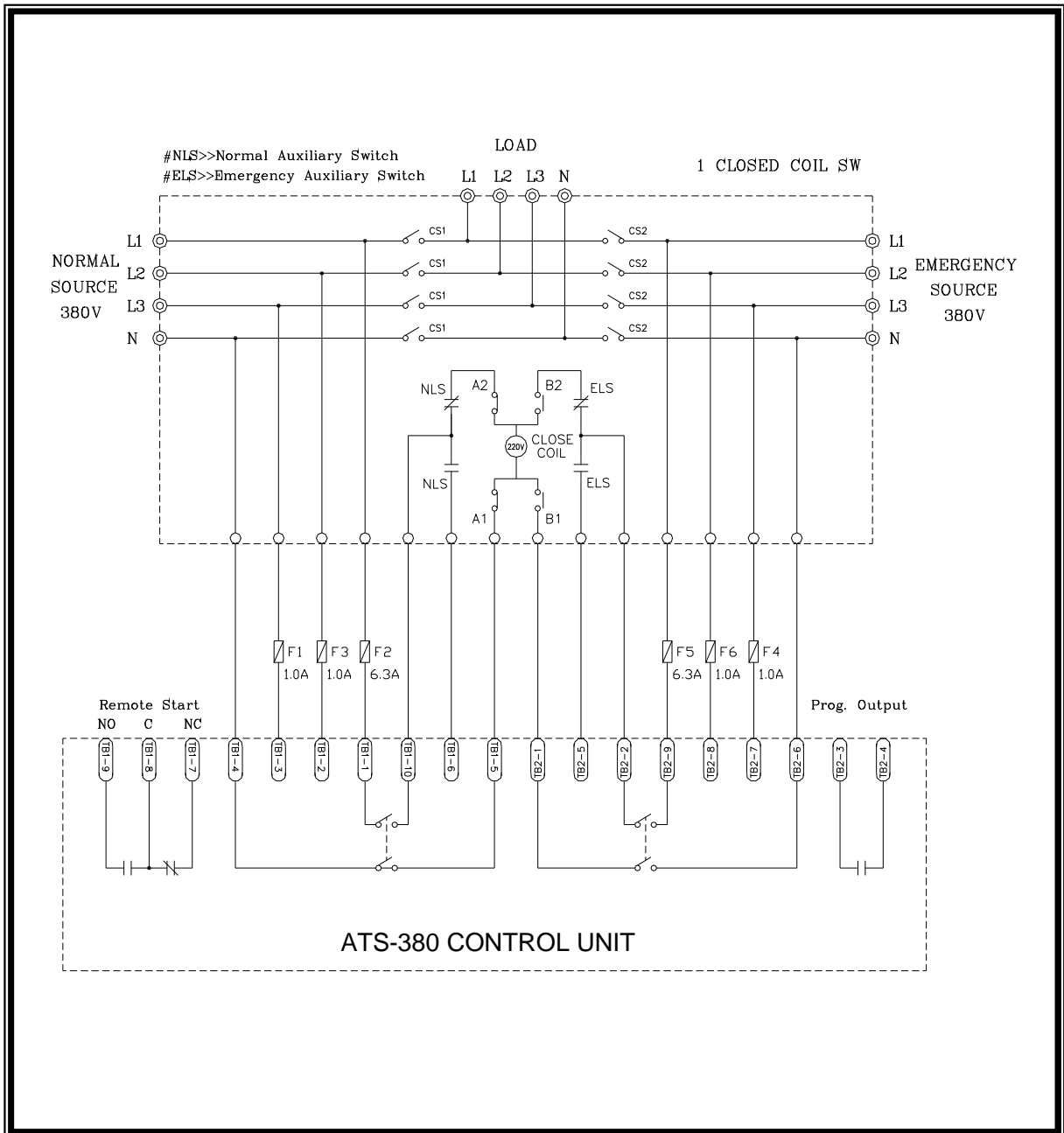

6.2.3 Two Coils Double Throw Type Wiring Diagram

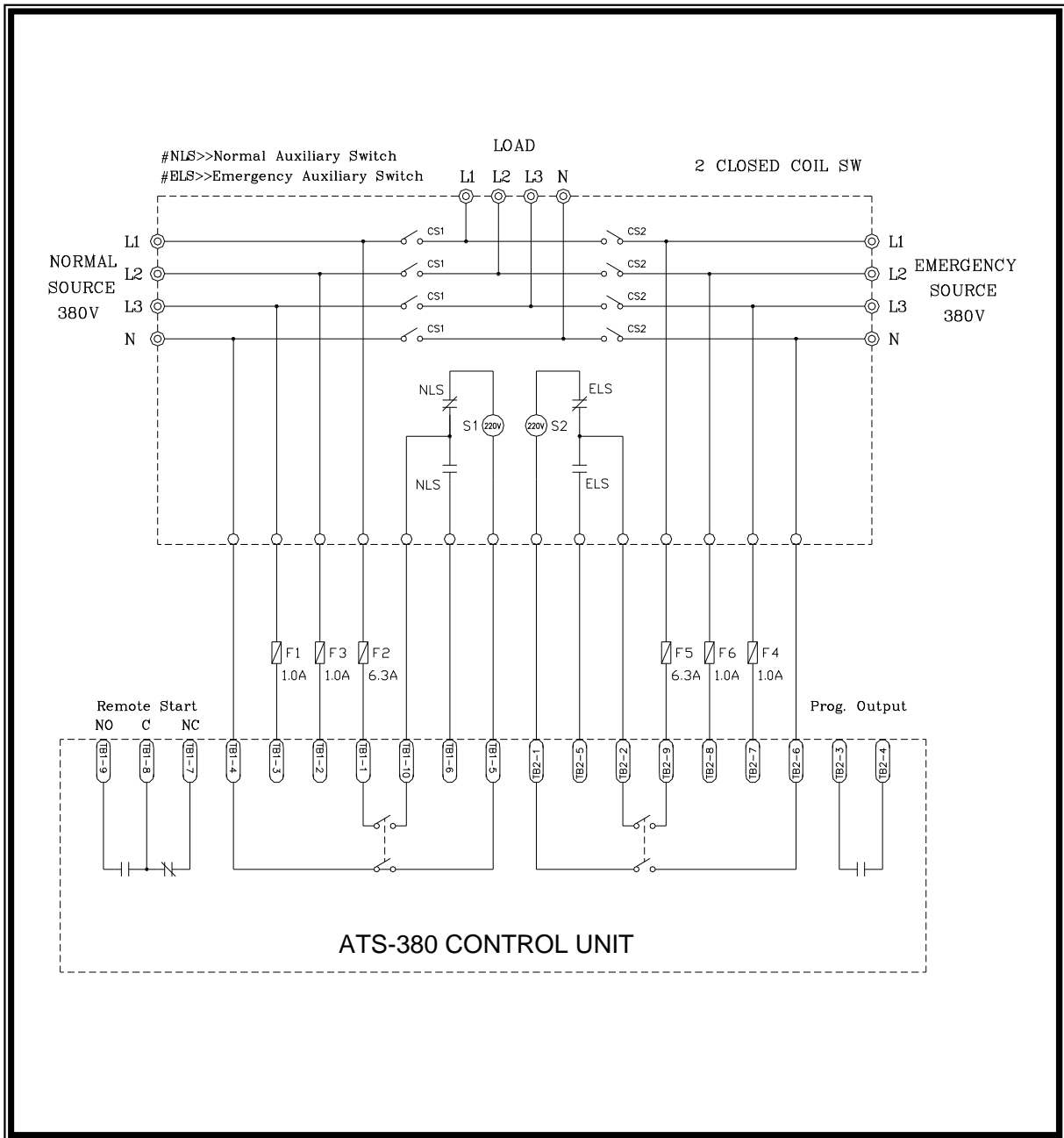

6.2.4 Magnetic Contactor Type Wiring Diagram

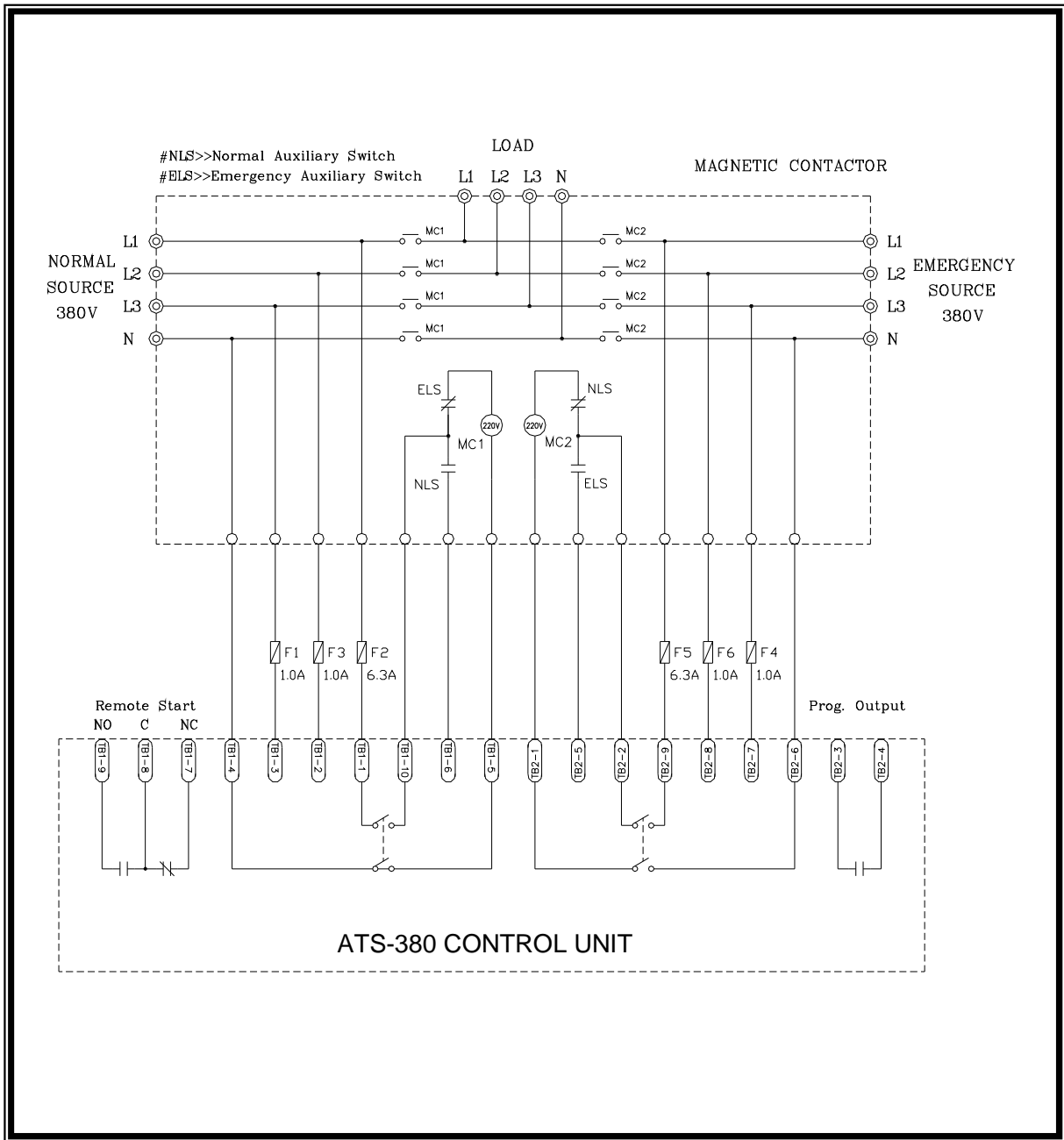

6.3 3P 380V Connecting Wire Diagram

6.3.1 MCCB Type Wiring Diagram

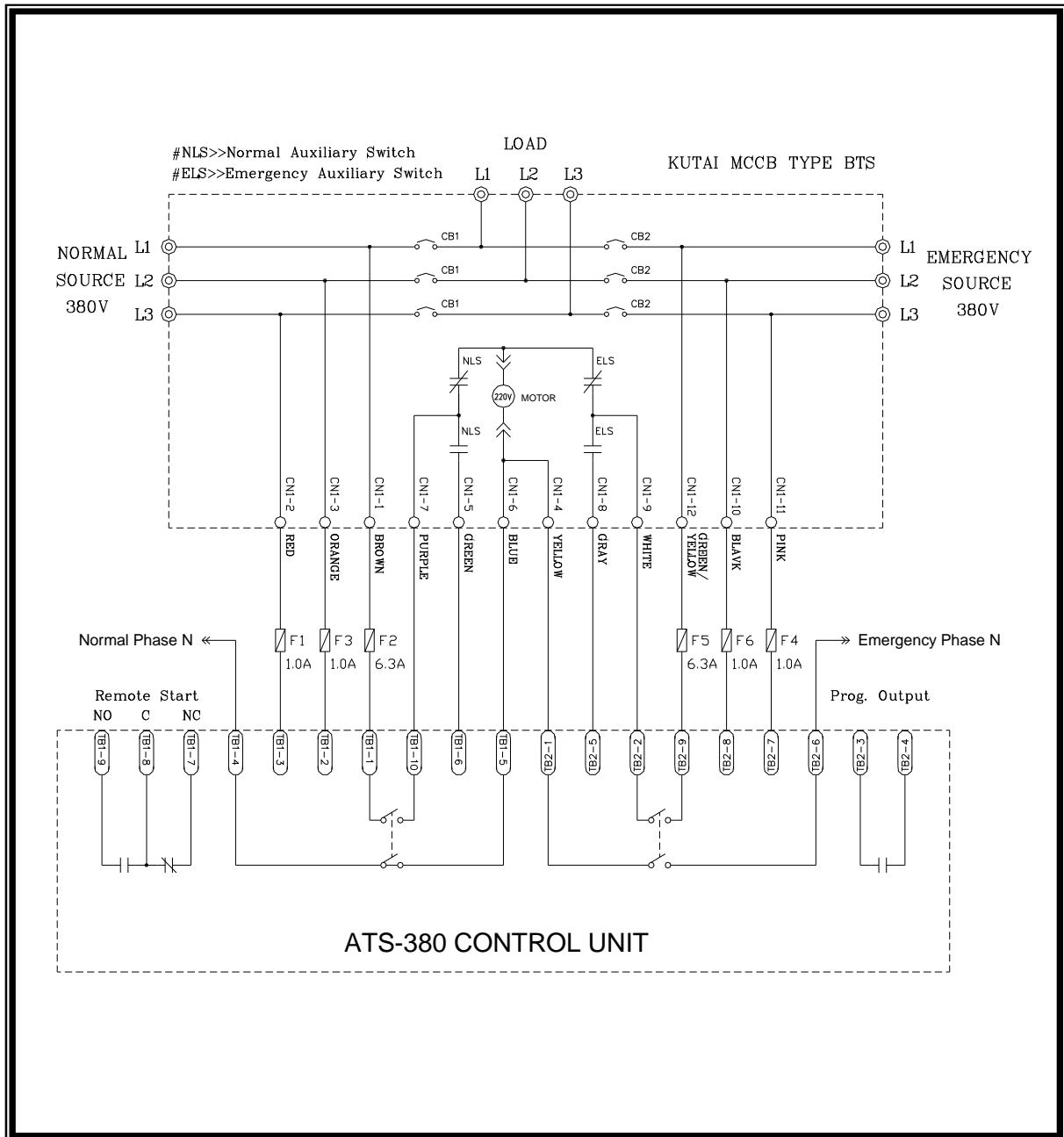

6.3.2 One Coil Double Throw Typical Wiring Diagram

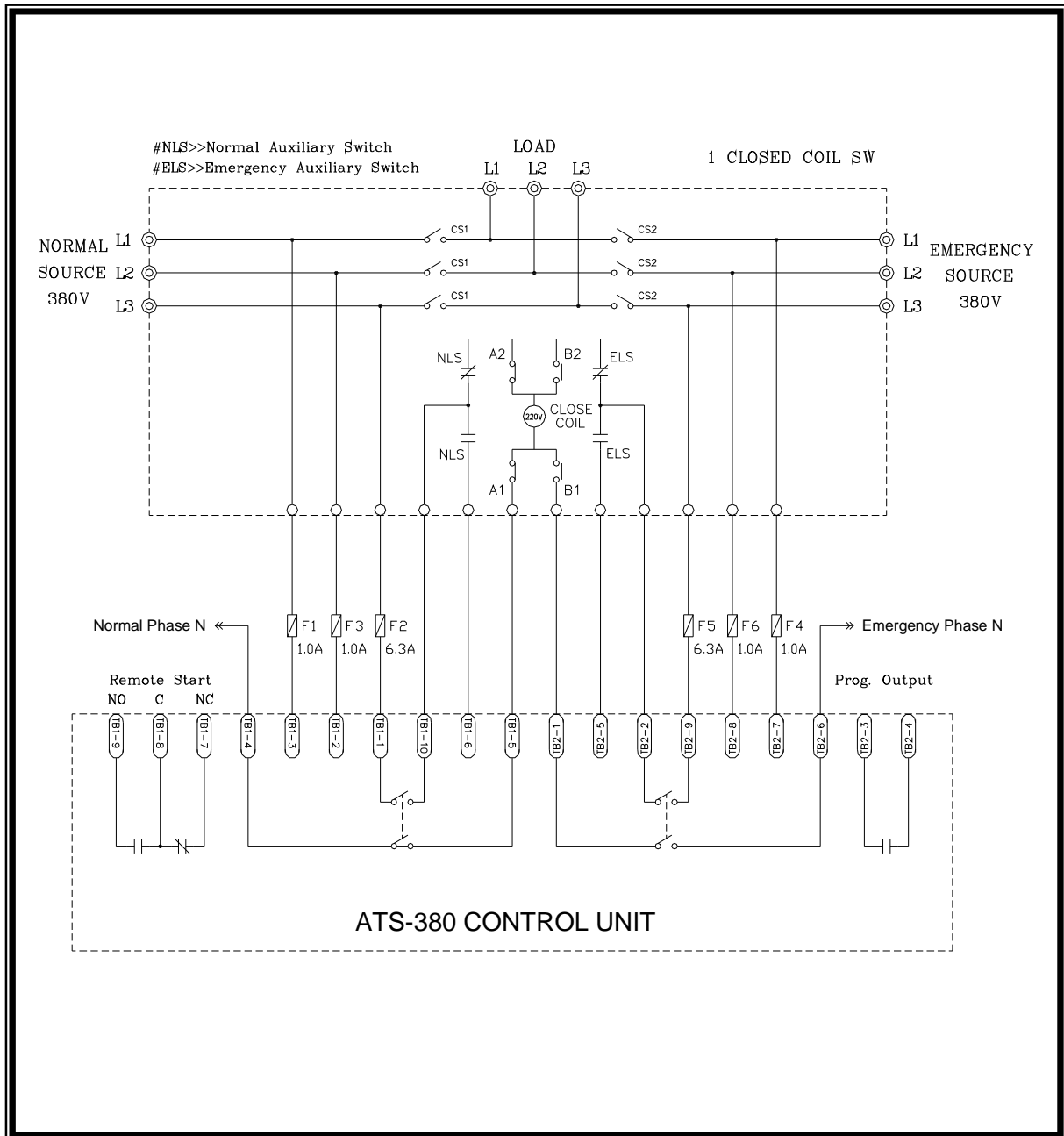

6.3.3 Two Coils Double Throw Type Wiring Diagram

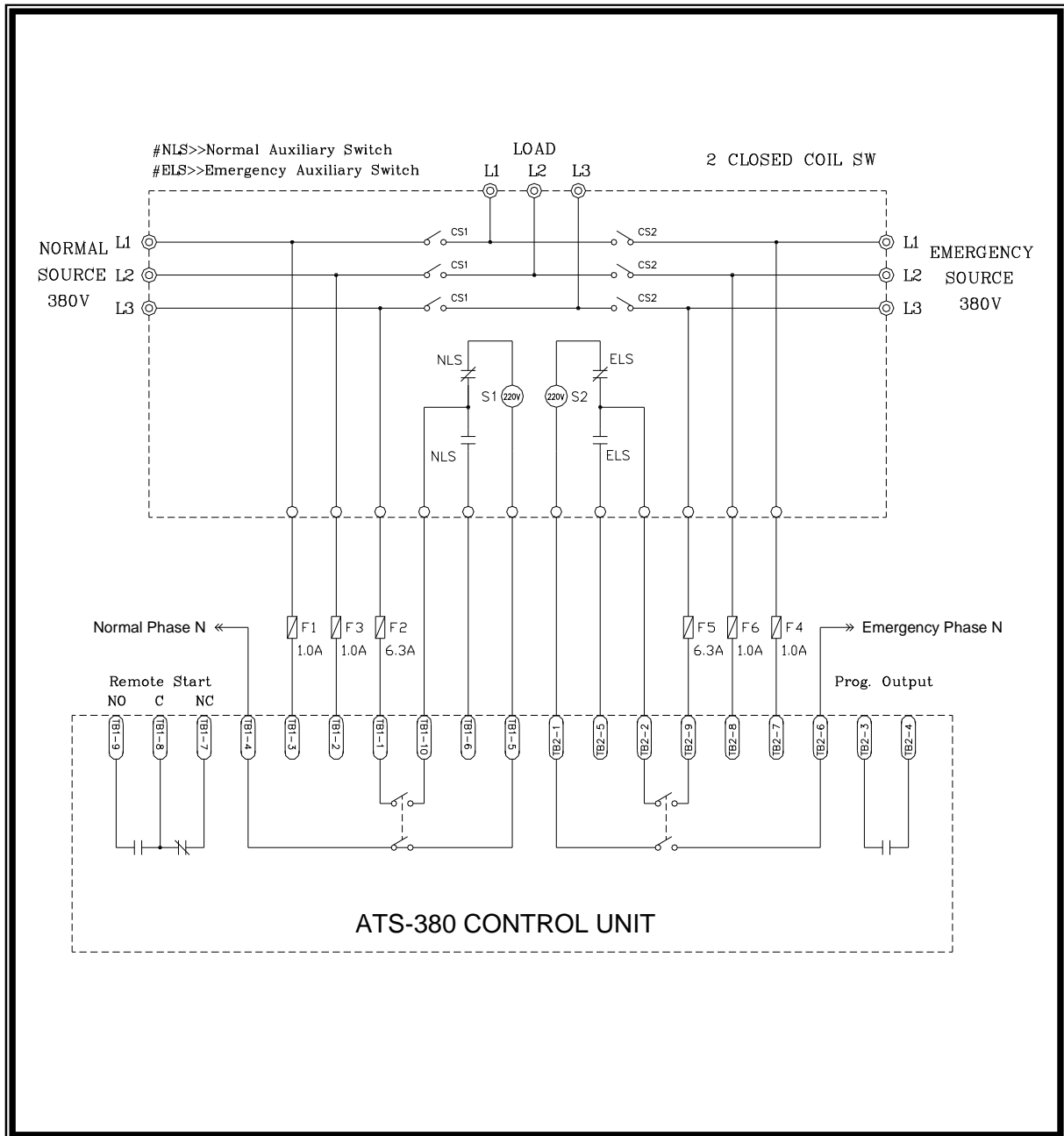

6.3.4 Magnetic Contactor Type Wiring Diagram

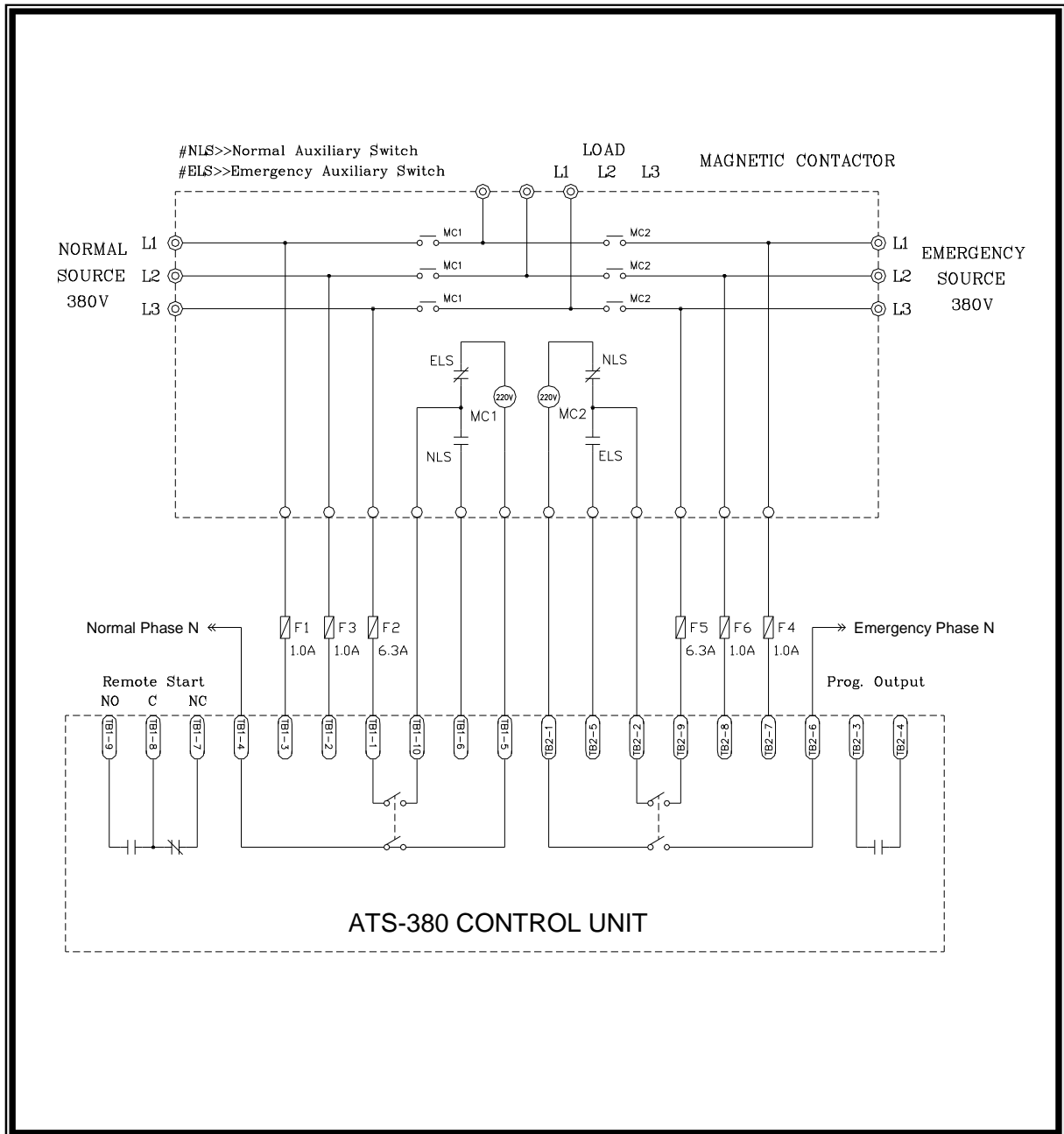

6.4 Single Phase 380V Connecting Wire Diagram

6.4.1 MCCB Type Wiring Diagram

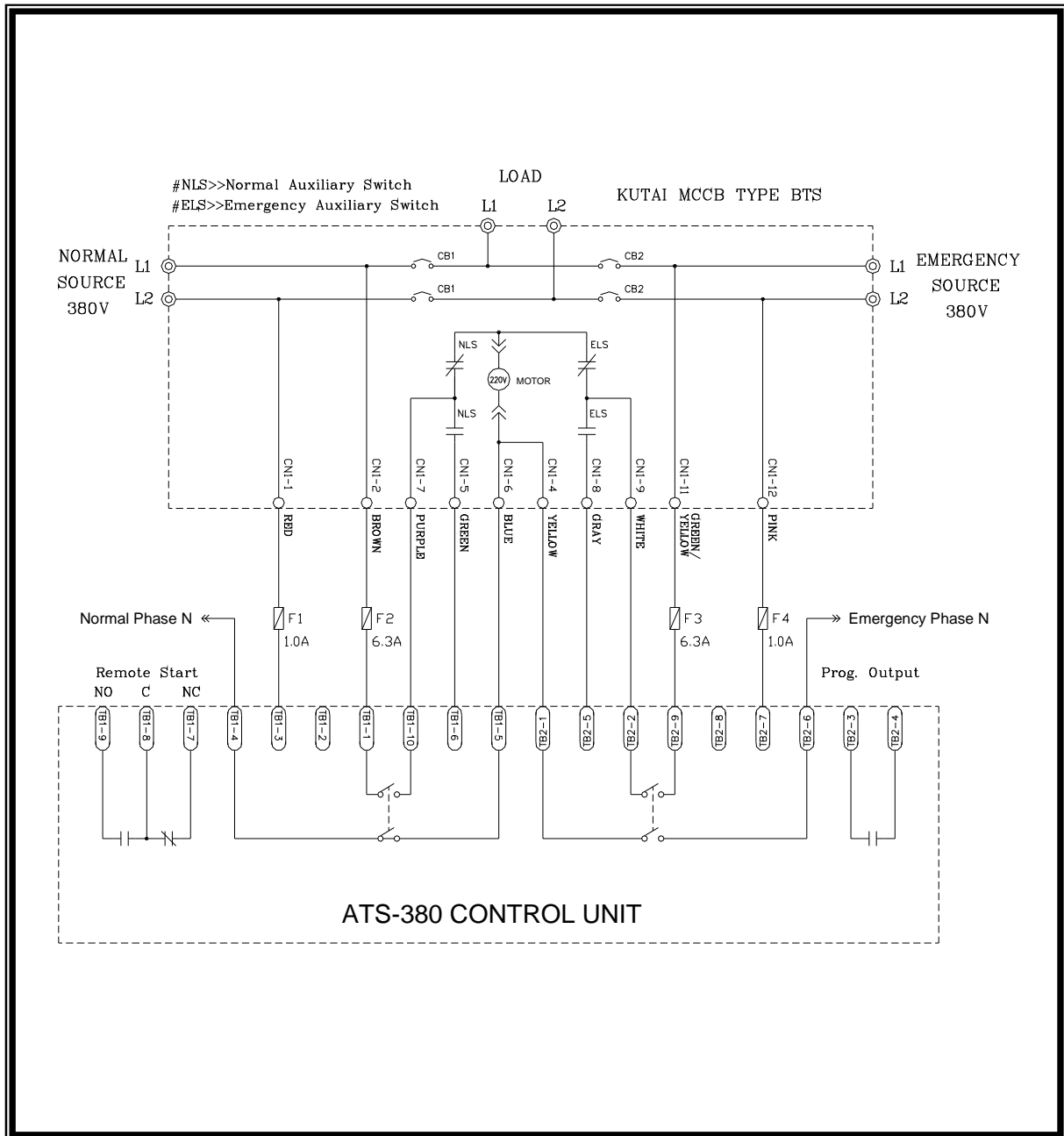

6.4.2 One Coil Double Throw Typical Wiring Diagram

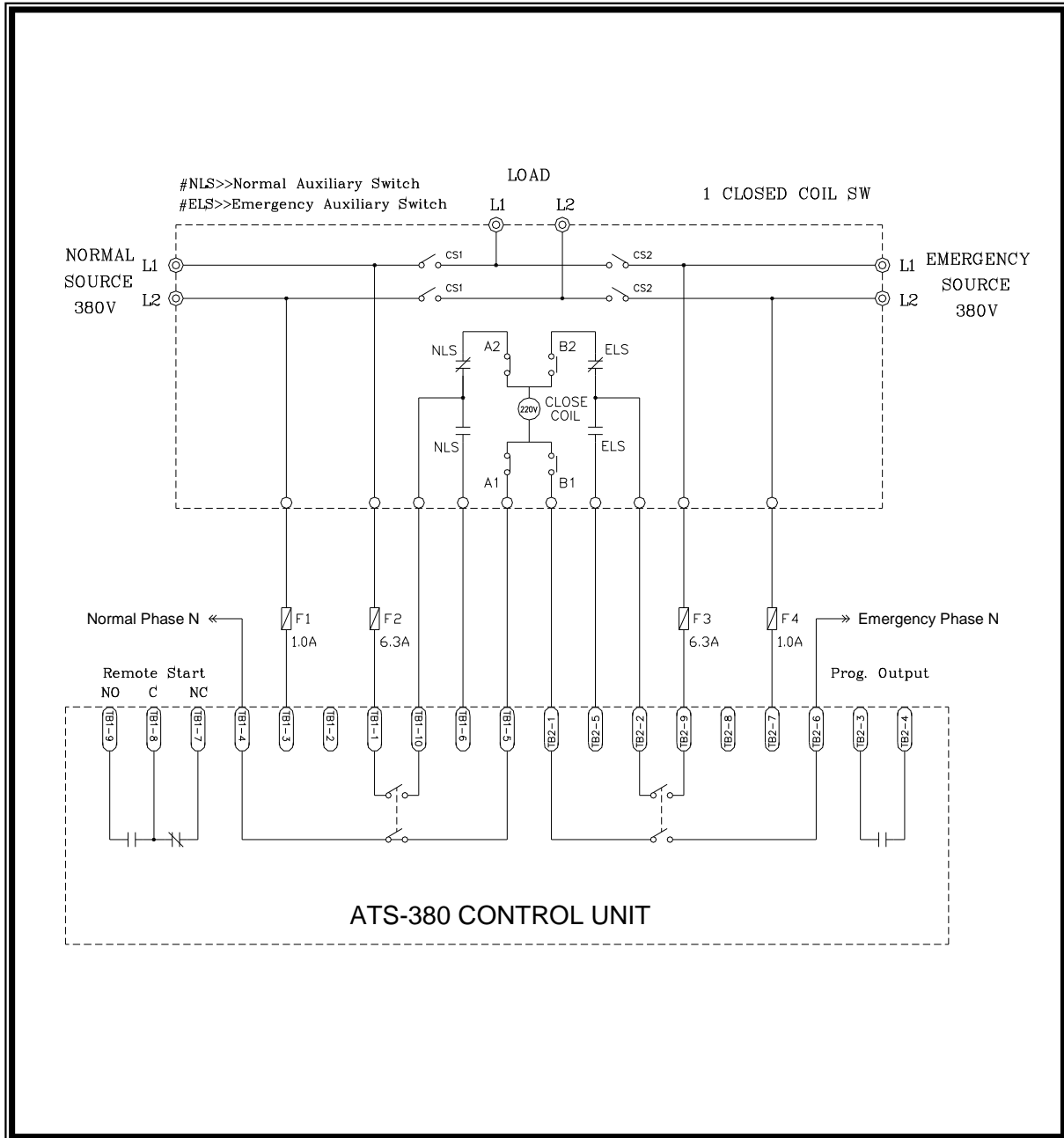

6.4.3 Two Coils Double Throw Type Wiring Diagram

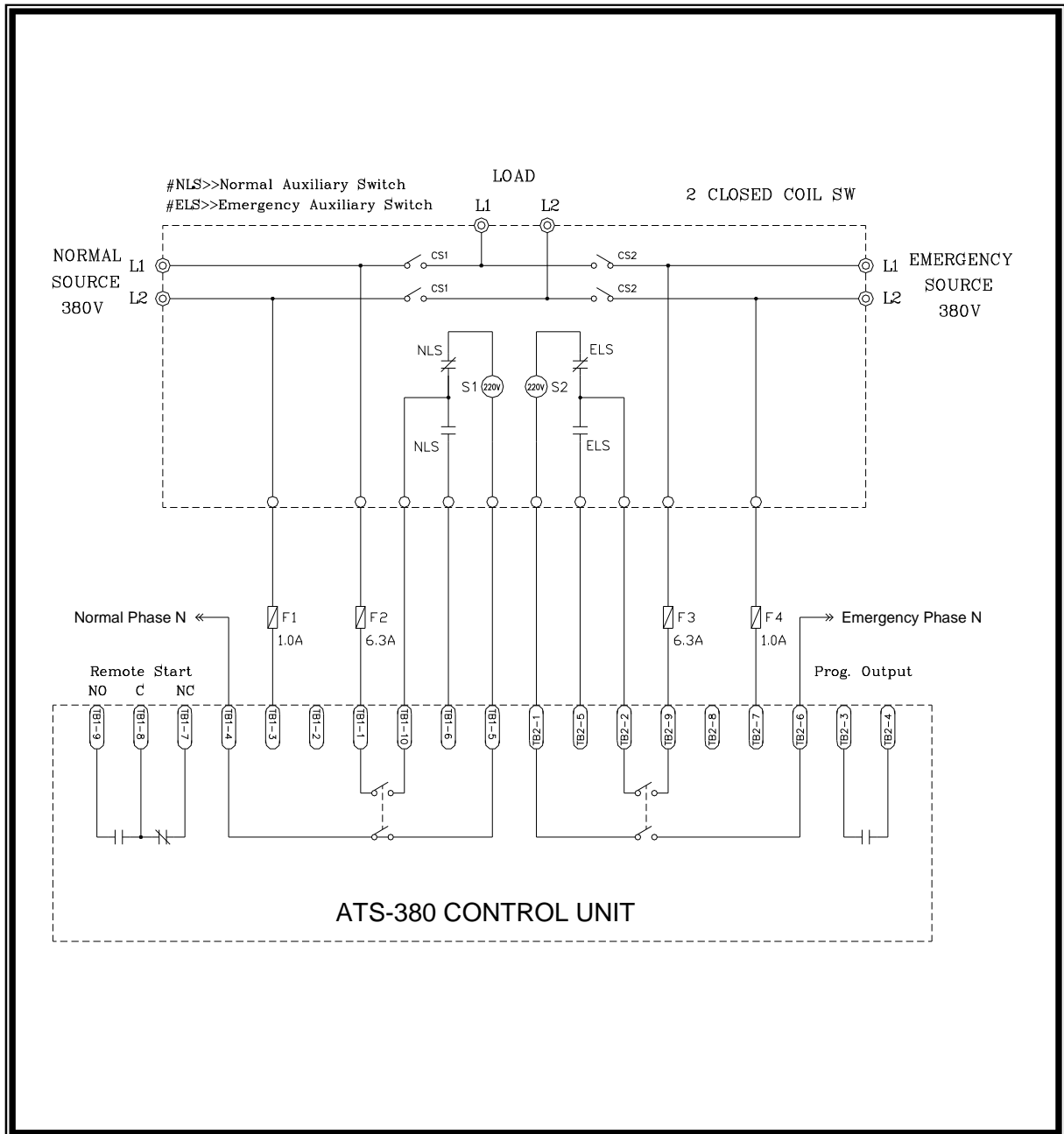

6.5 Connecting Wire Diagram When The Switch Transfer Current Over 6 Amps

6.5.1 MCCB Type Wiring Diagram

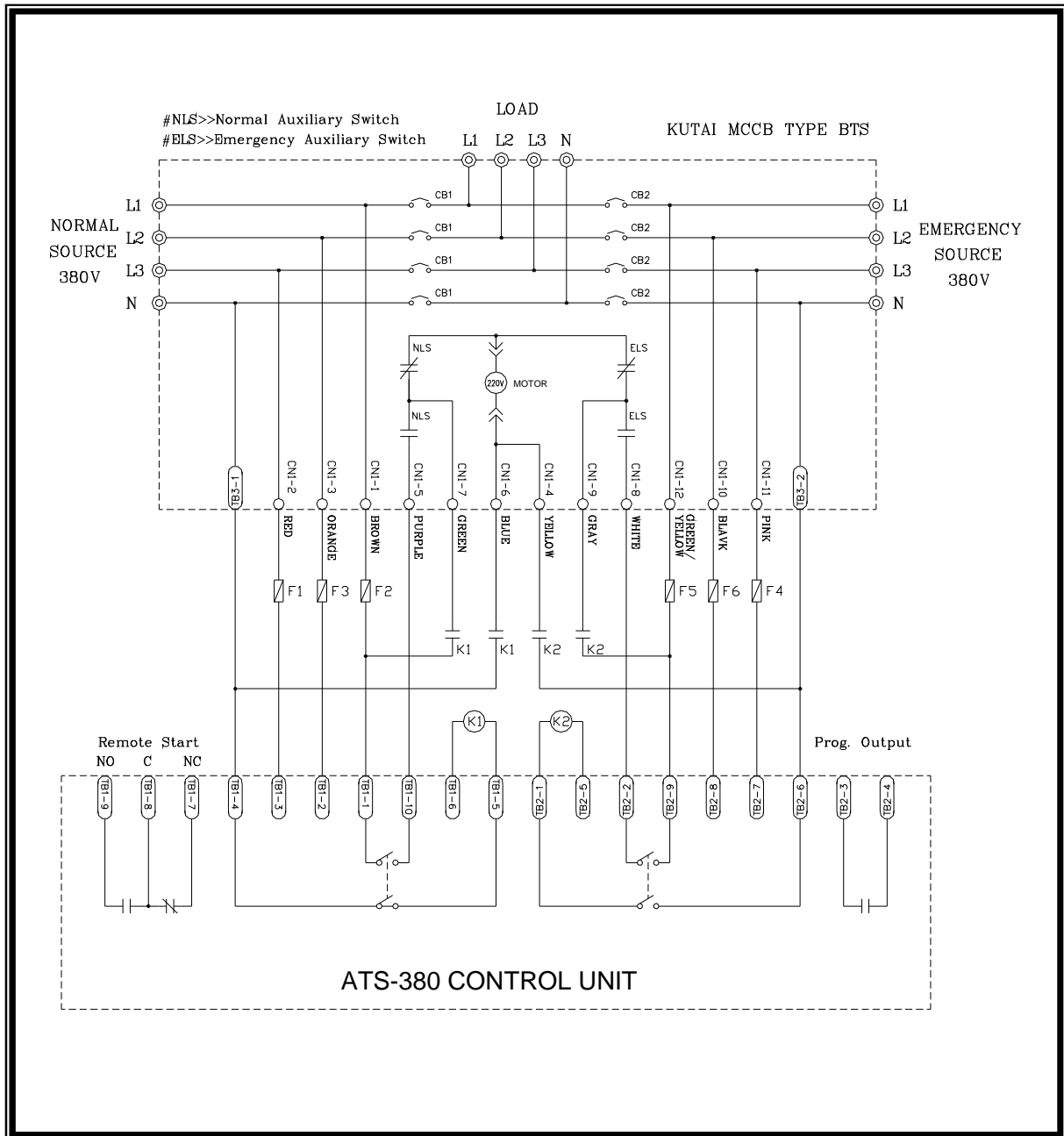

6.5.2 One Coil Double Throw Typical Wiring Diagram

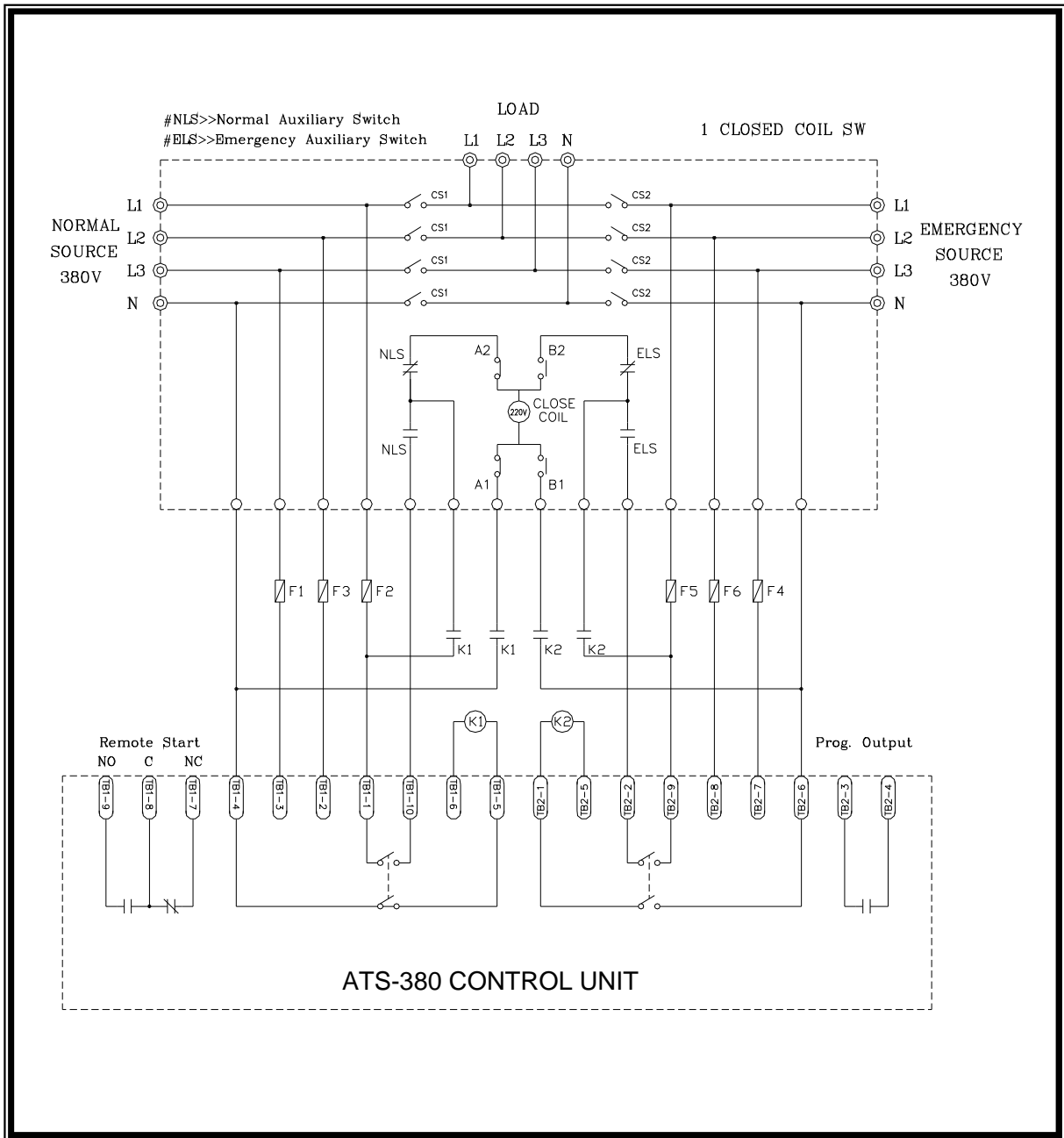

6.5.3 Two Coils Double Throw Type Wiring Diagram



6.5.4 Magnetic Contactor Type Wiring Diagram

