

TSP-04

ACB Type ATS Transformer Module

With Multi-Voltage Plug-In Connectors to Simplify ATS Set-up
For ACB Type ATS Use Only*1

Features

- Use in System Voltage from 100 to 500 VAC*2 *3
- Connect to ACB*4 & ATS-01*5 by Plug-in Connectors
- Select Voltage Directly by Plug-in Connectors
- Save Labor Cost by Easy Assembly & Maintenance
- Circuits Are Finger Safe with High Voltage Fuses & UL94-V0 Epoxy Protection
- Built-in 3 Phase Fuses to Protect Normal & Emergency Circuits in ATS-01 & TSP-04
- Provide Prog. output & Engine Start Contacts



TSP-04
www.kutai.com.tw

Specifications

Fuse	Function	Current	Fuse Capacity	Plug-In Connectors	Range	Universal Voltages
F1	Protect Normal Power Circuit	6.3A	50 KA @ 500 VAC	100-120 VAC	±10%	100 , 110 , 120
F2	Protect Normal Power Circuit	6.3A	50 KA @ 500 VAC	200-240 VAC	±10%	200 , 220 , 240
F3	Protect Normal Power Circuit	6.3A	50 KA @ 500 VAC	380-420 VAC	±10%	380 , 401 , 415
F4	Protect Emergency Power Circuit	6.3A	50 KA @ 500 VAC	440-480 VAC	±10%	440 , 460 , 480
F5	Protect Emergency Power Circuit	6.3A	50 KA @ 500 VAC			
F6	Protect Emergency Power Circuit	6.3A	50 KA @ 500 VAC			

Connector	Function	Capacity	Connector	Function	Capacity
Remote Start	Remote Engine Start	250 VAC / 7A	TB2	Connect to ATS-01	300 VAC / 15A
Prog. Output	Programmable Output	120 VAC / 0.5A	TB3,TB4,TB5	Connect to ACBs	600 VAC / 8A
CN1,CN2,CN3,CN4	Connect to Internal Transformers	600 VAC / 8A			

Mechanical Specifications (Unit : mm)

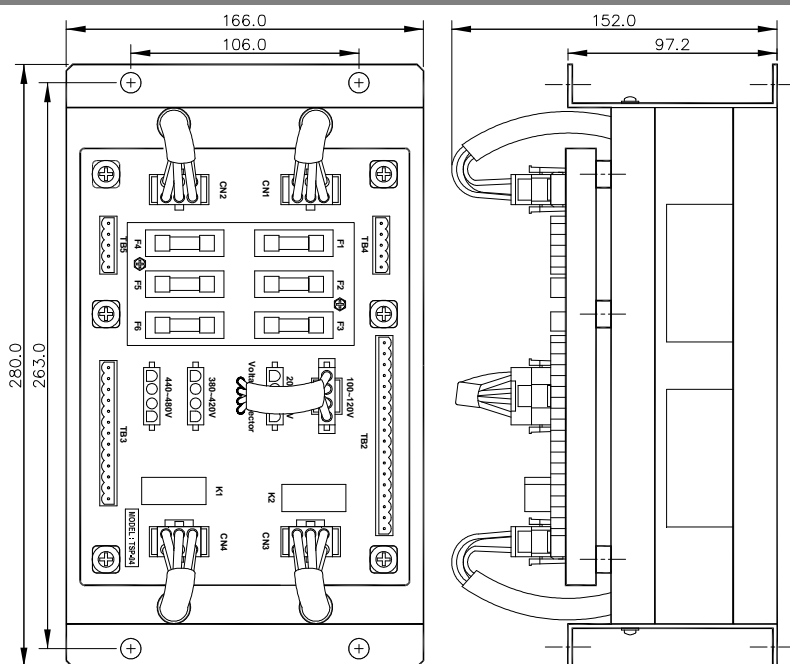

Physical Specification

Dimensions 280.0 (L) x 166.0 (W) x 152.0 (H) mm

Weight 5.5 Kg ±2%

- *1 TSP-04 is for ACB Type ATS Used Only.
- *2 The Rate Capacity of TSP-04 is 105 VA.
- *3 TSP-01 is for General Transfer Switch used.
- *4 ACB Type ATS : Air Circuit Breaker Type Transfer Switch
- *5 ATS-01 : Programmable ATS Controller

