

EA04A

Generator Automatic Voltage Regulator Operation Manual



Self Excited Automatic Voltage Regulator
Compatible With Basler VR63-4 & VR63-4A*

* Use for reference only and not genuine Basler product.



固也泰電子工業有限公司
KUTAI ELECTRONICS INDUSTRY CO., LTD.



Headquarters : No.3, Lane 201, Chien Fu ST., Chyan Jenn Dist., Kaohsiung, TAIWAN

Tel : + 886-7-8121771

Fax : + 886-7-8121775

URL : <http://www.kutai.com.tw>

1. SPECIFICATION

Sensing & power Input

Voltage	90 ~ 132 VAC / 171 ~ 264 VAC DIP switch selectable
Frequency	50 / 60 Hz, selectable

Output

Voltage	Max. 32 VDC @ 120 VAC input Max. 63 VDC @ 240 VAC input
Current	Continuous 4A Intermittent 7A for 60 sec.
Resistance	Min. 15 ohm Max. 100 ohm

Voltage Regulation

< $\pm 1\%$ (with 4% engine governing)

Voltage Build-up

Residual voltage at AVR terminal > 5 VAC

Thermal Drift

0.05% per °C change in AVR ambient

External Volts Adjustment

$\pm 15\%$ with 1K ohm 1 watt trimmer

EMI Suppression

Internal electromagnetic interference filtering

Unit Power Dissipation

Max. 8 watt

Under Frequency Protection (Factory Setting)

50 Hz system presets knee point at 45 Hz

60 Hz system presets knee point at 55 Hz

Over Excitation Shutdown

Field volts shut down after a time delay if exciter field volts exceed 100 ± 5 VDC.

Beyond 135 VDC, field volts will be removed immediately

Dimensions

100mm L * 68.5mm W * 33mm H

Weight

230 g $\pm 2\%$

2. FREQUENCY COMPENSATION

The frequency compensation characteristic to improve system load pickup performance by restraining voltage recovery until frequency has also started to recover.

For 50Hz system, the regulator is preset at the factory for a 45Hz "corner frequency". For 60Hz systems, a 55Hz "corner frequency". is achieved by cutting the external Hz jumper wires on the generator. Be sure to insulate the two wires so that they are not exposed.

3. OVEREXCITATION SHUTDOWN

If the exciter field voltage exceeds 100 ± 5 VDC, the regulator automatically removes the field current after a time delay. The time delay is inversely proportional to the magnitude of the detected over voltage condition up to the 135 VDC point. Beyond 140 VDC, the field voltage is removed within 0.2 seconds.

After shutdown, reset the regulator by decreasing voltage below 6 VAC either by stopping the prime mover or interrupting the regulator input with a reset switch for 2 seconds or more.

4. VOLTAGE ADJUST RHEOSTAT

Screwdriver adjustable potentiometer adjusts generator output voltage. Adjustment CW increases voltage.

When using remote voltage adjust rheostat (VAR), the VAR wire on the regulator should be cut and the rheostat connected to both ends. A 1k ohm and 1 watt resistance is adequate for most applications. See Interconnection Diagrams.

5. FIELD FLASHING

When the regulator is operated with the generator for the first time, the polarity residual magnetism may not correct or the magnitude not enough. If the generator does not build-up after shartup, shut down the prime mover and proceed with the following steps:

- 5.1 With the prime mover at rest, apply a DC source (not grounded) of not more than 12V, to terminals F+ (positive) and F- (negative) in series with a limiting resistor of 3 ~ 5 ohms.
- 5.2 Allow approximately 3 seconds before removing the dc source.

- 5.3 Start prime mover and measure voltage at regulator leads 3 and 4. If voltage is greater than 5 volts, voltage build-up should be successful. Repeat field flashing procedure if less than 6V residual is measured.
- 5.4 If repeating steps 1 and 2 does not result in generator voltage build-up, replace the voltage regulator.

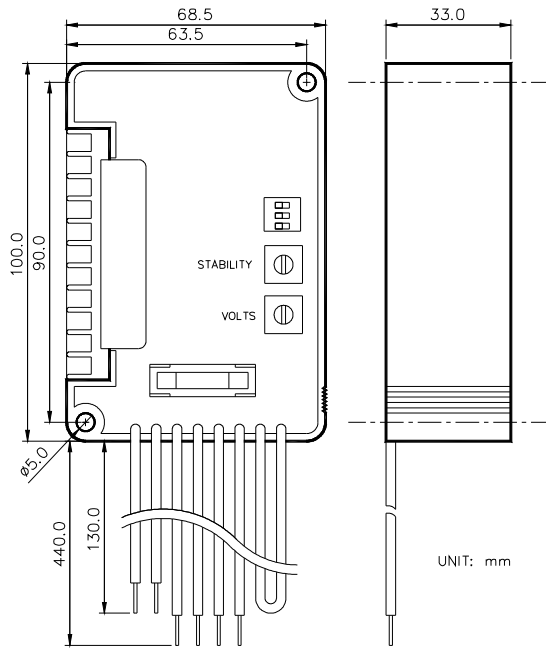

Outline Dimension
Figure 1

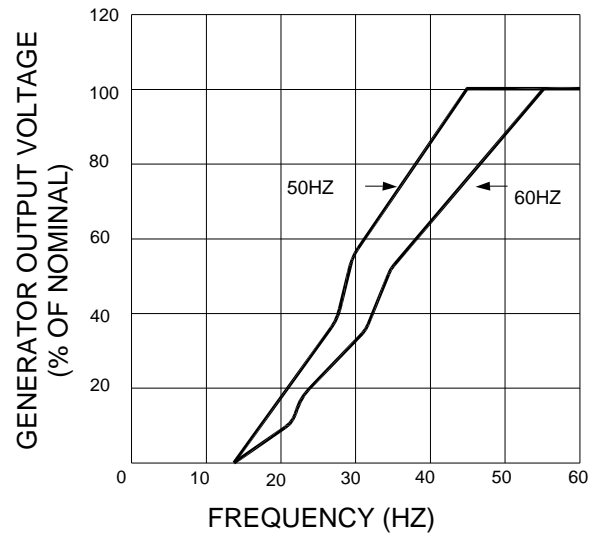

Frequency Compensation Curves
Figure 2

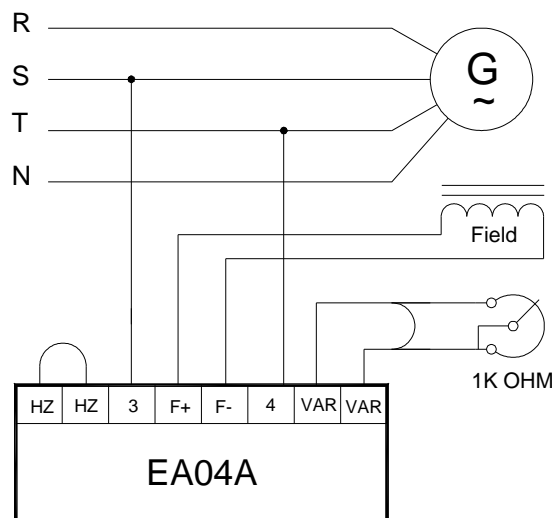

Interconnection Diagram, 208 ~ 240V Nominal
Figure 3