



---

## 1. SPECIFICATION

### Sensing & power Input

Voltage	160 ~ 265 / 300 ~ 550VAC DIP switch selectable
Frequency	45 / 65 Hz, selectable

### Output

Voltage	Max. 32 VDC @ 120 VAC input Max. 63 VDC @ 240 VAC input
Current	Continuous 4A Intermittent 7A for 60 sec.
Resistance	Min. 15 ohm    Max. 100 ohm

### Voltage Regulation

< ± 1% ( with 4% engine governing )

### Voltage Build-up

Residual voltage at AVR terminal > 5 VAC

### Thermal Drift

0.05% per °C change in AVR ambient

### External Volts Adjustment

±15% with 1K ohm 1 watt trimmer

### EMI Suppression

Internal electromagnetic interference filtering

### Unit Power Dissipation

Max. 8 watt

### Under Frequency Protection ( Factory Setting )

60 Hz system presets knee point at 55 Hz ±4%  
50 Hz system presets knee point at 45 Hz ±4%  
DIP switch selectable

### Over Excitation Shutdown

Field volts shut down after a time delay if exciter field volts exceed 100 ± 5 VDC.  
Beyond 135 VDC, field volts will be removed immediately

### Operating temperature

-40°C (-40°F) to +60 °C (+140°F)

### Storage temperature

-65°C (-85°F) to +85 °C (+185°F)

### Dimensions

101mm L \* 69mm W \* 47.3mm H

### Weight

230 g ± 2%

## 2. WIRING (Refer to Fig3)

- Power input 3, 4.
- Sensing input 4, P.
- F + 、 F- : Exciter.
- EXT.VAR : External Voltage Adjustment.  
DIP switch 1 on for sensing 105 ~ 265Vac.  
DIP switch 2 on for sensing 300 ~ 550Vac.

## 3. FREQUENCY COMPENSATION

The frequency compensation characteristic to improve system load pickup performance by restraining voltage recovery until frequency has also started to recover.

For 50Hz system, the regulator is preset at the factory for a 45Hz "corner frequency".

For 60Hz systems, a 55Hz "corner frequency".

DIP switch 2 on for 50 Hz generator system.

DIP switch 2 off for 60 Hz generator system.

## 4. OVEREXCITATION SHUTDOWN

If the exciter field voltage exceeds 100 ± 5 VDC, the regulator automatically removes the field current after a time delay. The time delay is inversely proportional to the magnitude of the detected over voltage condition up to the 135 VDC point. Beyond 140 VDC, the field voltage is removed within 0.2 seconds.

After shutdown, reset the regulator by decreasing voltage below 6 VAC either by stopping the prime mover or interrupting the regulator input with a reset switch for 2 seconds or more.

## 5. STARTUP PROCEDURE

### 5.1 Setting

1. Ensure the AVR model and the generator are compatible.
2. Ensure all the wires of the regulator are correctly connected.

3. Ensure proper fuse is installed.
4. Turn voltage and stability potentiometer full anticlockwise (lowest voltage level).
5. If used, turn external voltage potentiometer to the middle position.
6. Use 600 VAC Voltage meter connect to AC output terminal and measure the output voltage.

### 5.2 Startup Procedure

1. To start and run the generator at no load and rated speed. The generator output voltage should build up to a minimum level if the voltage does not build up, It may cause by low residual voltage of generator. Refer to field flashing section in generator manual.
2. Slowly adjust voltage potentiometer until the generator voltage reach the proper value.

## 6. STABILITY ADJUSTMENTS

1. Slowly rotate the STAB control in the clockwise (CW) direction will change the AVR and generator's response time, if over adjusted the voltage will become unstable, if under, the instant heavy load voltage will change significantly.

2. It is advised to use a voltmeter DCV to adjust the STAB control F+, F- until the oscillate becomes minor. By doing so helps to improve and reduce the voltage change under heavy load.

## 7. FIELD FLASHING

When the regulator is operated with the generator for the first time, the polarity residual magnetism may not correct or the magnitude not enough. If the generator does not build-up after startup, shut down the prime mover and proceed with the following steps:

1. With the prime mover at rest, apply a dc source (not grounded) of not more than 12V, to terminals F+ (positive) and F- (negative) in series with a limiting resistor of 3 ~ 5 ohms.
2. Allow approximately 3 seconds before removing the dc source.
3. Start prime mover and measure voltage at regulator leads 3 and 4. If voltage is greater then 5 volts, voltage build-up should be successful. Repeat field flashing procedure if less than 6V residual is measured.
4. If repeating steps 1 and 2 does not result in generator voltage build-up, replace the voltage regulator.

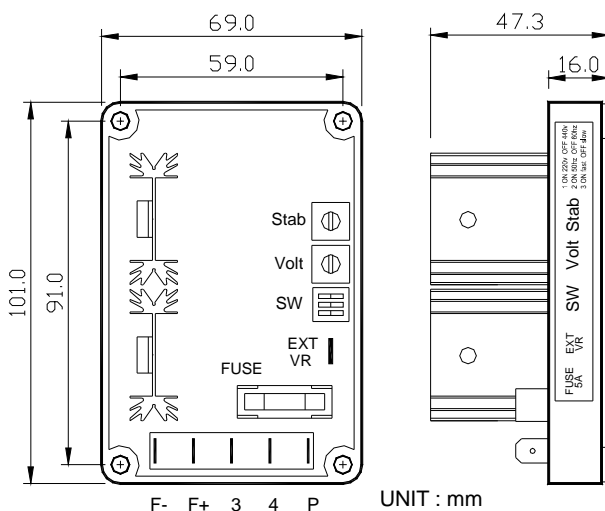

Outline dimension  
Figure 1

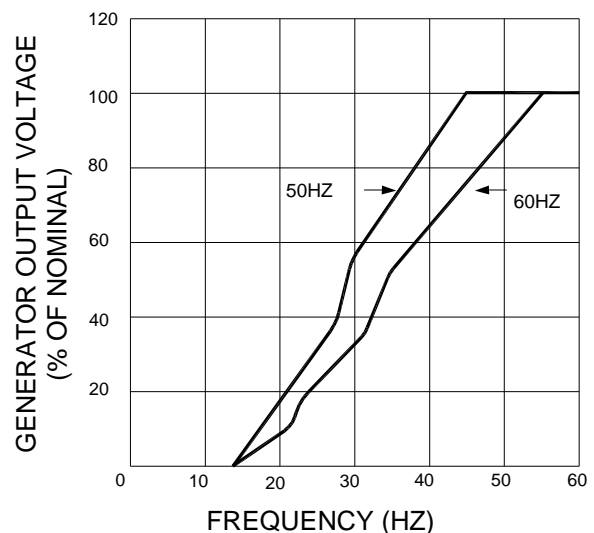

Frequency compensation curves  
Figure 2

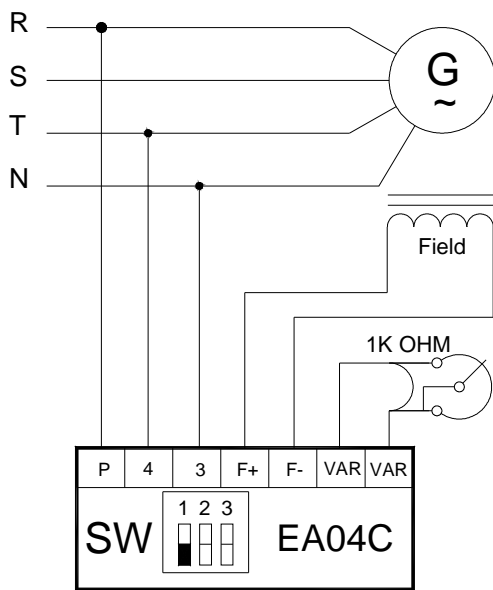

※ SW-1 OFF for 380/480VAC system  
(3Ø 4W 380/480 VAC)

Figure 3

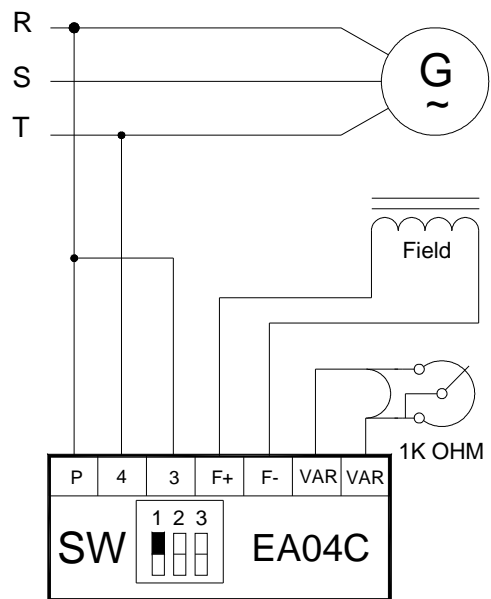

※ SW-1 On for 220VAC system

Figure 4

## 8. SW DESCRIPTION

- (1) SW-1 Sensing voltage selector  
ON for 220V OFF for 380 / 480V.
- (2) SW-2 Frequency selector  
ON for 50Hz OFF for 60Hz.
- (3) SW-3 Response  
ON for fast OFF for slow.

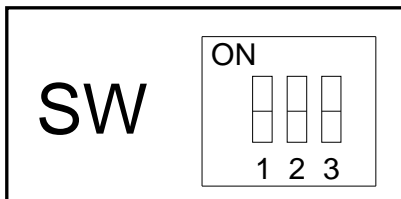

### Ac Power Input :

3, 4 90~240VAC 50/60HZ

### Sensing Input :

P, 4 160~265VAC 50/60HZ  
300~550VAC 50/60HZ

### Dc Output Power :

F+, F- MAX 63VDC 4A

### EXT.VAR (1 KΩ)

CLOSE "HZ" JUMP 50HZ  
OPEN "HZ" JUMP 60HZ

### CAUTION

Meggers and high potential test equipment must not be used. Incorrect use of such equipment could damage the semiconductors contained in the regulator.

※ Use only original supplied spare protection fuse for fuse replacement.

※ Please accept our sincere apology if any modification in performance, specification or appearance is made without prior notice.