

# EW05

## *Generator Automatic Voltage Regulator Operation Manual*

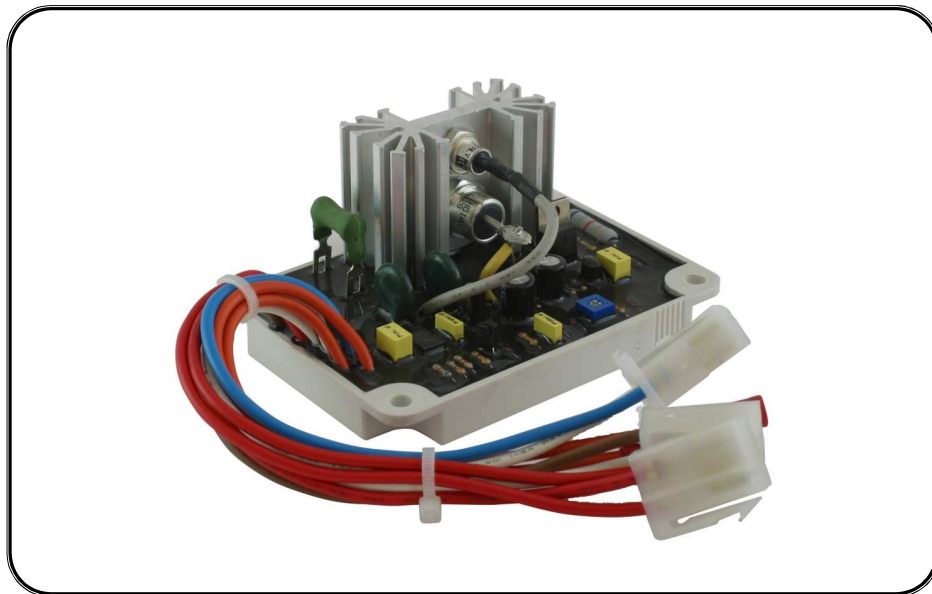

Welder Automatic Voltage Regulator  
Compatible with 190 / 200 / 210 Type



**固也泰電子工業有限公司**  
**KUTAI ELECTRONICS CO., LTD.**



**Headquarters** : No.3, Lane 201, Chien Fu ST., Chyan Jenn Dist., Kaohsiung, TAIWAN

**Tel** : + 886-7-8121771

**Fax** : + 886-7-8121775

**URL** : <http://www.kutai.com.tw>

---

## 1. INTRODUCTION

### Power Input

Voltage 90 ~ 130 VAC, 1 phase 2 wire

### Output

Voltage 45 VDC

Current Continuous 5A  
Intermittent 15A for 10 sec

Voltage 110 VDC

### Voltage Build-up

Residual voltage at AVR terminal > 2 VAC

### Thermal Drift

0.05% per °C change in AVR ambient

### Current Compensation

Automatic welding current compensation

### Current Adjustment

Welding current 50 ~ 190 A

### Dimensions

104mm L \* 75mm W \* 48mm H

### Weight

212g ± 2%

## 2. WIRING AND ADJUSTMENT

### ATTENTION !

INSTALLATION, WIRING, ADJUSTMENT AND INSPECTION MUST BE DONE BY PROFESSIONAL PERSON.

- The regulator should be installed in the place where are clean and ventilated. Avoid moisture, corrosiveness and careless touched.
- The temperature of heat sinker will reach 60 C in normal operation.

Do not touch heat sinker to prevent personal injury or electric shock when regulator is operating.

### 2.1 OPERATION PROCEDURE

1. Be sure all the wiring is properly connected.
2. Be sure the specification of fuse is 5A 250VAC.
3. Turn the voltage trimmer fully anticlockwise.
4. Monitoring F+ / F- output with DC voltmeter.
5. Monitoring AC output with AC voltmeter.
6. Start engine and turn the idle switch off. Adjust engine speed to proper value under no load.

Then the generator should establish voltage rapidly. If failed to establish voltage. Refer the procedure of "Excite the field with battery" stated below or seek advise from local wholesaler.

### 2.2 EXCITE GENERATOR WITH BATTERY

In case of residual voltage of generator is not enough to establish voltage. External excite is necessary.

**WARNING**

Over excite with battery will caused regulator or generator damaged.

Connect battery 3 ~ 24V, 100 ohm resistor > 5 watts and one push button switch with wiring diagram as below. When the voltage of generator reach 30% of rated voltage the action must stop immediately.

7. Turn the idle switch on; setup the engine speed to expected lowest value. Then the output voltage of generator will drop to 70 ~ 85VAC.

### NOTICE !

On this situation using inductive load is prohibited.

### 2.3 WELDING OPERATION

Idle switch should put in ON position. Engine speed will increased according as welding current generated. Exciting voltage compensation takes place to accompany with welding current increased.

The value of voltage compensation is depended on the preset welding current intensity.

APPLICABLE MODULES	
Alternator Brand	Part Number
SUZUKI	CCW-210、CCW-190H
HONDA	EW-190S
DAISHIN	SGW-200HX
KAIYU	SGW-190X

**NOTE :**

- For excite voltage compensation purpose either wire #6 or #9 must pass through the CT, which is located on, IDLE control board.
- When engine starting put idle switch to off position is helpful to establishing voltage.

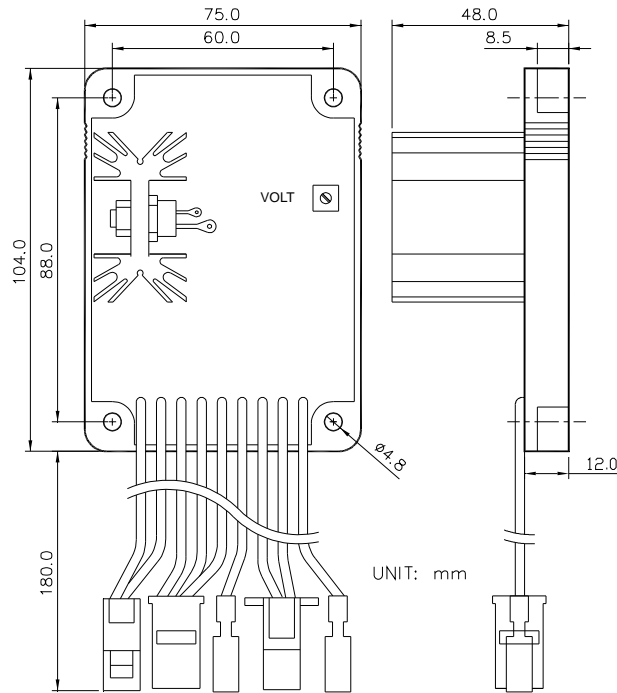

Outline Drawing  
Figure 1

TERMINAL NUMBER	DESCRIPTION
1	Alternator Output 12VAC
2	Alternator Output 12VAC
3	Input 110VAC
4	Input 110VAC / F+ Output
5	F- Output
6	Current Transformer
7	External Potentiometer
8	External Potentiometer
9	Current Transformer

Utility Description for Connector

