

# AMF-10 Ver1.0

## *Automatic Mains Failure Automatic Genset Control and Protection Module*



**固也泰電子工業有限公司**  
**KUTAI ELECTRONICS INDUSTRY CO., LTD.**



**Headquarters** : No.3, Lane 201, Chien Fu ST., Chyan Jenn Dist., Kaohsiung, TAIWAN

**Tel** : + 886-7-8121771

**Fax** : + 886-7-8121775

**URL** : <http://www.kutai.com.tw>

## TABLE OF CONTENTS

| <i>Section</i>  | <i>Page</i> |
|---|-------------|
| <b>ATTENTION</b> .....                                      | 3           |
| <b>PROJECT BACKGROUND</b> .....                             | 3           |
| <b>INTRODUCTION</b> .....                                   | 3           |
| <b>AMF-10 MONITORING AND PROTECTION FUNCTION</b> .....      | 3           |
| <b>1. FRONT PANEL LAYOUT</b> .....                          | 4           |
| 1.1 Front Panel Layout.....                                 | 4           |
| 1.2 Rear panel layout .....                                 | 5           |
| 1.3 Unit Dimensions (Measurement : mm).....                 | 6           |
| 1.4 Panel Cut-out (Measurement : mm) .....                  | 6           |
| <b>2. OPERATION</b> .....                                   | 7           |
| 2.1 Summary.....  | 7           |
| 2.2 Auto Mode Of Operation .....                            | 7           |
| 2.3 Off Mode Of Operation.....                              | 8           |
| 2.4 Manual Mode Of Operation.....                           | 8           |
| 2.5 Test Mode Of Operation.....                             | 8           |
| <b>3. SYSTEM SETTING &amp; OPERATION</b> .....              | 9           |
| 3.1 DC Input .....  | 9           |
| 3.2 System Setting .....                                    | 9           |
| 3.3 Operation timer setting.....                            | 9           |
| 3.4 AC Voltage & Current Display Setting .....              | 10          |
| 3.5 Engine Over-Load Protection Setting .....               | 10          |
| 3.6 User Specified Monitoring Setting Alarm1 & Alarm2 ..... | 10          |
| 3.7 Service & Maintenance Setting.....                      | 11          |
| 3.8 Panel display setting .....                             | 11          |
| 3.9 Engine Idle Operating Function .....                    | 11          |
| 3.10 Automatic Transferring Switch (ATS) function.....      | 11          |
| 3.11 Communication with PC (KCU-XX).....                    | 11          |
| 3.12 System Setting Reference Table .....                   | 12          |
| <b>4. SYSTEM WARNING FAILURE DESCRIPTION</b> .....          | 15          |
| 4.1 Failure signal reference table.....                     | 15          |
| 4.2 Warning Mode.....                                       | 15          |
| 4.3 Shutdown Mode .....                                     | 15          |
| <b>5. SPECIFICATION</b> .....                               | 15          |
| <b>6. TERMINAL &amp; WIRING DESCRIPTION</b> .....           | 16          |
| 6.1 Connection Detail.....                                  | 16          |
| 6.2 Wiring Diagram .....                                    | 17          |

## ATTENTION

This document is intended to cover the installation, operation and maintenance of the AMF-10 automatic genset control and protection module. It is a guide for qualified personnel.

Carefully read this manual before installation.

## PROJECT BACKGROUND

Automatic Transfer Switches protect electrical equipment against power loss. The normal power source (power grid) is backed up by a standby (emergency generator). The transfer switch is connected to both and is made to supply the load from either one. In the event power is lost from the normal source, the generator is started and the transfer switch transfers to standby power. Once normal power is restored, the ATS transferred back to the grid and waits for the next electrical failure.

The AMF-10 module constantly checks the power coming from the grid for problems related to over / under voltage or a missing phase.

## INTRODUCTION

The AMF-10 is one control with two jobs, one is to protect and control the emergency generator and the other is to monitor and control the Automatic Transfer Switch.

The customer can program the AMF-10 module directly from the front panel without using a computer. Any new settings are recorded into the internal (EEPROM) and protected from erasure even without battery.

The AMF-10 has 4 settings; Automatic (AUTO) - Manual (MANU) - Testing (TEST) and Shutdown (OFF) in addition to this four buttons the front panel has a 4 digital, 7 segment numerical displays showing all the alternating Volts, Amps and Hertz, Battery Volts and engine running Hours readings and the programming interface for changing all the engine, ATS and generator parameters.

The 4 Digital displays shows:

- Normal and emergency AC voltage
- Normal and emergency load current
- Normal and emergency AC frequency in Hertz

- Engine running hours meter
- DC battery voltage
- Also the display shows all time delays and countdown function as they occur
- It also displays the program setting parameters as you change or reprogram the module

You can also change the way the display works, it can either be fixed; changing from one value to the other by pushing a button or displaying each line for 2 sec. in succession.

In conclusion the AMF-10 offer all the necessary protection and monitoring needed for any standby power genset.

## AMF-10 MONITORING AND PROTECTION FUNCTIONS

- Normal power full phase over / under voltage monitoring and lost of phase
- Standby power full phase over / under voltage monitoring and lost of phase
- Standby power full phase load current monitoring
- Engine high water temperature protection
- Engine low oil pressure protection
- Engine over/under speed protection
- Engine start failure warning
- External emergency stop warning
- Battery over and under voltage monitoring
- Low fuel level monitoring

AMF-10 has 2 extra inputs for the customer to use and set-up, like fuel overflow, radiator water levels, etc.

# 1. FRONT PANEL LAYOUT

## 1.1 Front Panel Layout



| ICON | DESCRIPTION                        | ATTENTION   |
|------|------------------------------------|---|
|      | Decrease / Selection               | IN Program mode, press to decrease value<br>IN normal operation, press to display voltage, current or frequency   |
|      | SET / Failure Reset                | IN OFF mode, press and hold button for 4 seconds to enter Program mode<br>IN normal operation, press button to select and display phase L12, L23, L31<br>IN failure status, press to erase alarm signal |
|      | Increase / Selection               | IN Program mode, press to increase value<br>IN normal operation, press to display battery voltage or engine running hours   |
|      | Automatic                          | Press to go into Automatic mode   |
|      | Stop                               | Press to enter Shutdown / System Off mode   |
|      | Test                               | Press to enter Testing mode   |
|      | Manual                             | Press to go on Manual mode  |
|      | Engine Start                       | Manual engine start (ON MANUAL MODE ONLY)   |
|      | Engine Stop                        | Manual engine shutdown (ON MANUAL MODE ONLY)  |
|      | Normal Power<br>Connect to Load    | Manual Transfer the Switch from Emergency to Normal Position<br>(ON MANUAL MODE ONLY)   |
|      | Emergency Power<br>Connect to Load | Manual Transfer the Switch from Normal to Emergency Position<br>(ON MANUAL MODE ONLY)   |

## 1.2 Rear panel layout

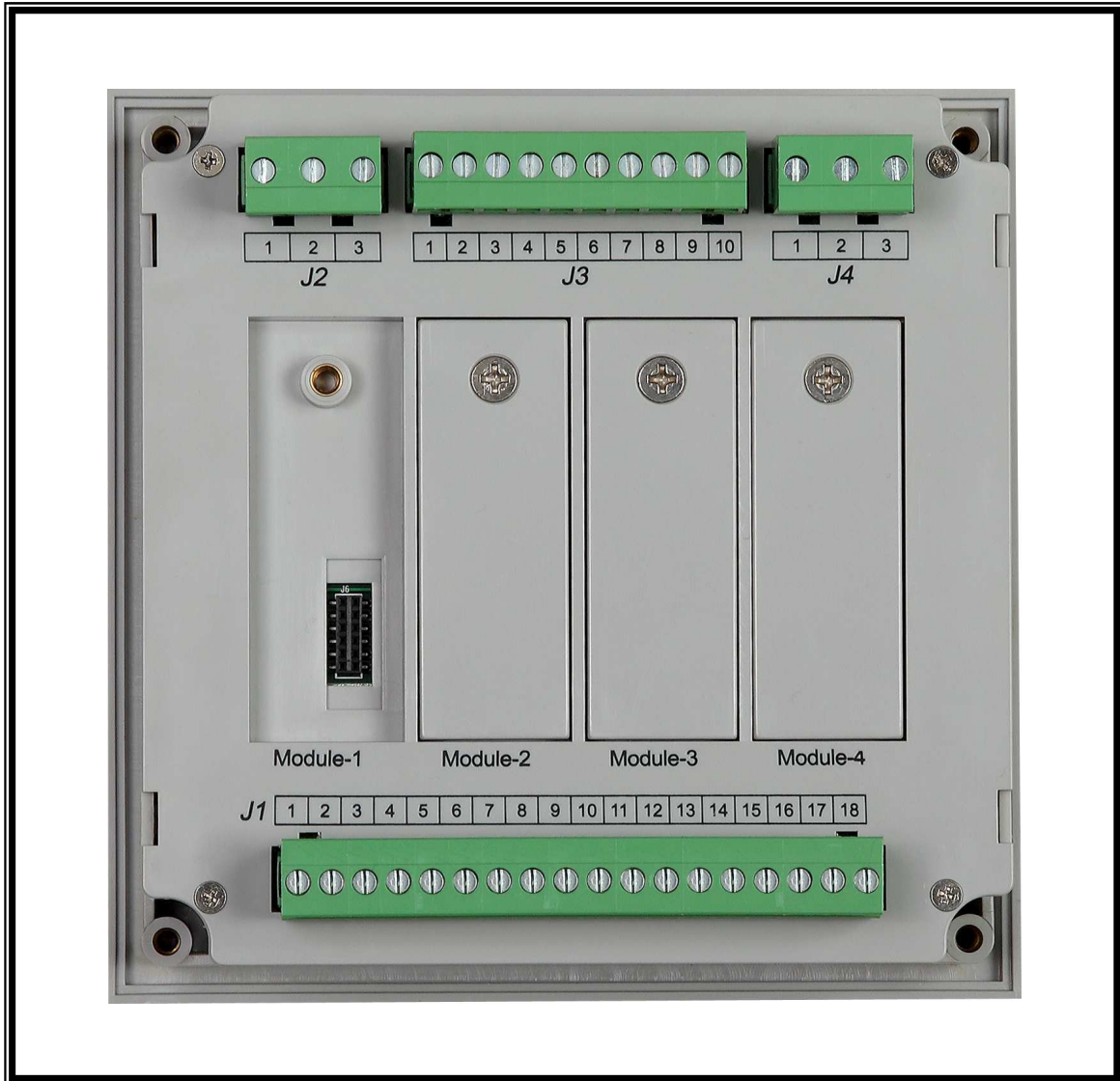

1.3 Unit Dimensions (Measurement : mm)

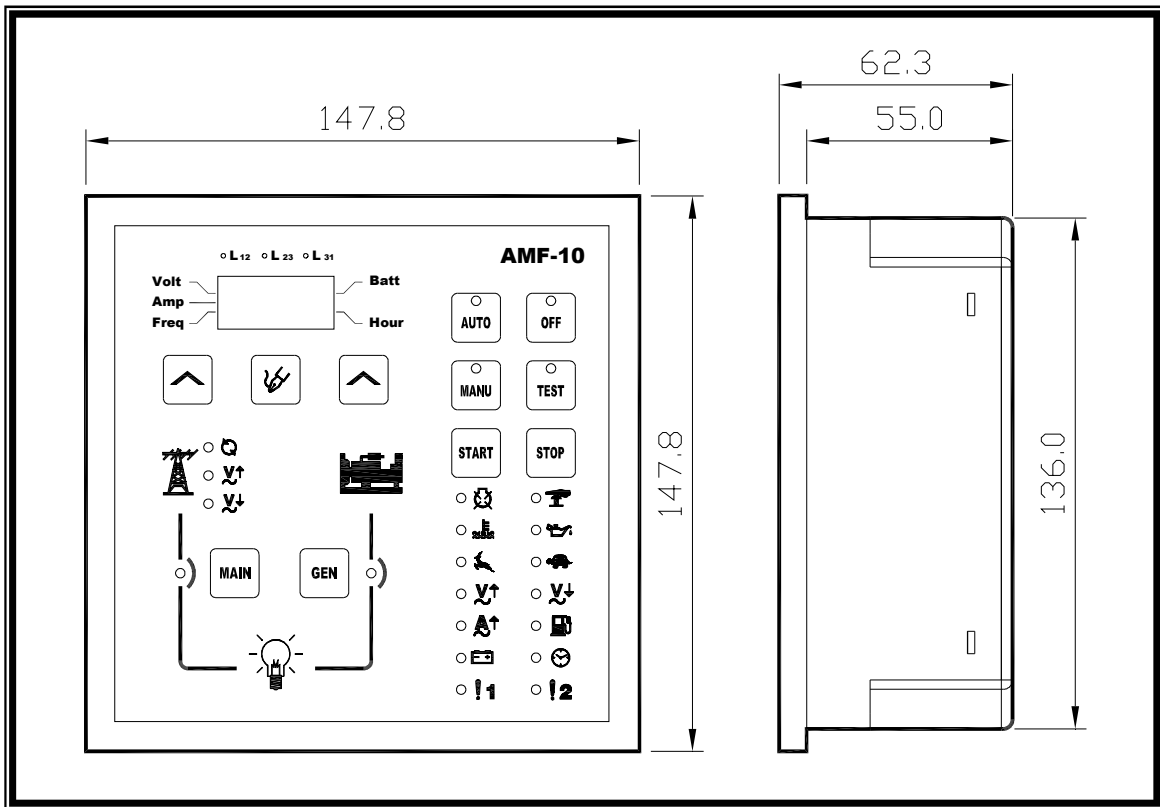

1.4 Panel Cut-out (Measurement : mm)

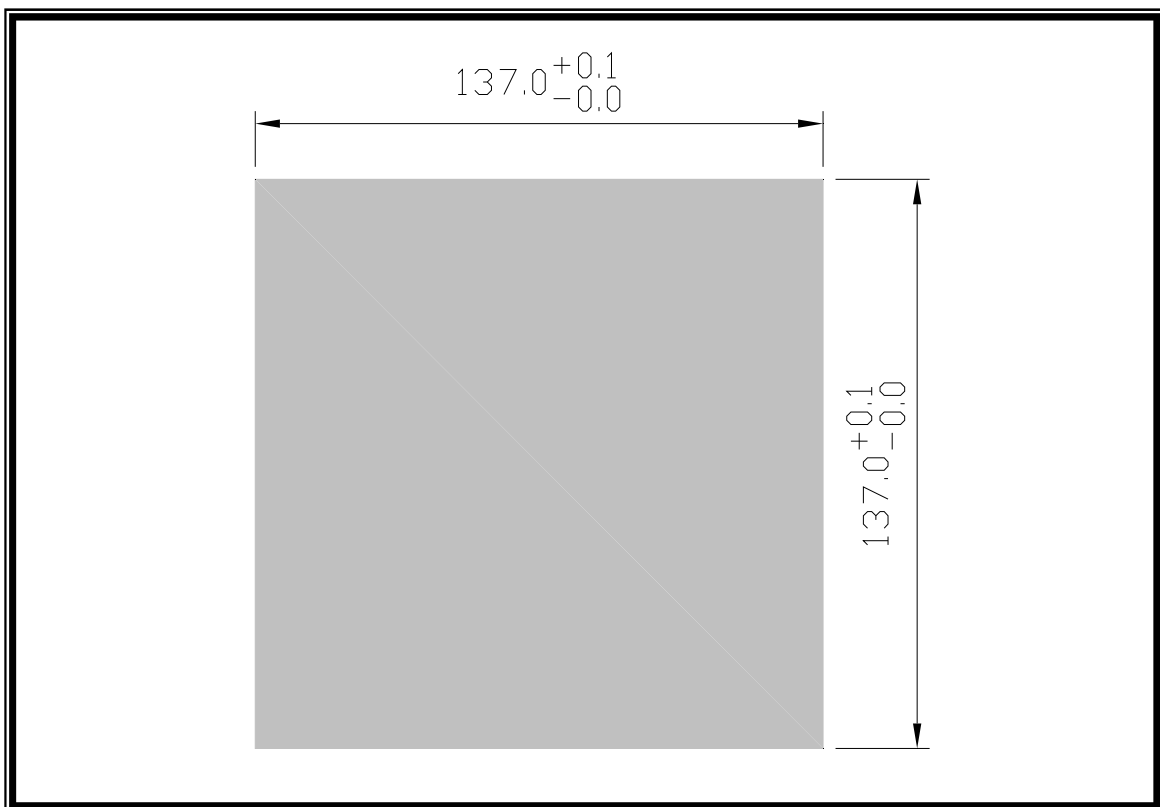

## 2. OPERATION

### 2.1 Summary

Operating the AMF-10, is divided into four functions; each one is controlled by a single push button located on the top right hand corner of the front panel.

1. AUTO : Automatic Operation
2. OFF : Shutdown/System OFF Mode
3. MANU : Manual Operation
4. TEST : Testing Mode

**(CAUTION)** only one operation mode can be selected at one time.

### 2.2 In Auto Mode of Operation

In **AUTO** mode, the **START - STOP - MAIN - GEN** buttons do not operate. They work only when the controller is in Manual operation. See paragraph 2.5.

Press the **AUTO** button and notice the **LED** lights-up confirming that you are in **AUTO**. In **AUTO** mode the **ATS** (Automatic Transfer Switch) and **genset** are directly controlled by the AMF-10.

The operation sequence in **AUTO** is as follows; when the AMF-10 detects any unusually voltage or no voltages or a missing phase coming from the normal (city grid), it automatically initiates the generator start sequences

First activating the engine Preheat, and at the same time displaying the Pre-Heat countdown in seconds **【PH.XX】** on the front screen.

Second, after the preheat times out, the starter motor begin to start and the screen displays the starter motor running time **【St.XX】** The starter motor runs for 6 sec. (the user can change the running time of the starter motor for up to 30 seconds) If the engine fails to start the first time, the AMF-10 returns to Preheat and tries again. The AMF-10 tries 3 times (the user can also change how many times the engine tries to start - up to 9 times).

If the engine fails to start, the AMF-10 lights-up the LED for Start Failure icon, and the screen flashes, **FAIL**.

But if the engine starts normally the AMF-10 immediately disengages the starter motor.

Disengaging the starter is vital to prevent damage to the starter motor and ring gear, and is done by sensing.

- Engine Oil pressure switch on
- AC voltage builds up
- AC frequency over 18Hz

Next the AMF-10 goes into idle (only if you have the proper engine governor idle connection), the screen shows **【Id.XX】**. Each entered value equals to 5sec idle delay (see page 12). To disable enter 0 and the engine will not idle.

After engine starts, the AMF-10 enters a 30sec grace period, delaying any shutdowns, and giving the generator time to reach normal engine speed, together with oil pressure, AC voltage and other operating parameter, the screen displays **【Ac.XX】** after confirming that everything is running OK.

But if the genset does not run normally before the 30sec grace period is up, the module shutdown the generator displaying the reason for stopping the genset on the front panel.

Now if the generator stabilizes and reaches its rated output, The AMF-10 starts the TDNE (Time Delay Normal to Emergency) countdown, showing **【nE.XX】** on the front screen. (Remember that each entered value is equals to 5sec delay, the preset TDNE countdown is 10sec, See page 12). When the countdown stops, the module sends a signal to the transfer switch to change-over from normal to emergency (standby generator) power. If the transfer switch fails to do this in 15sec, the AMF-10 flashes emergency on LED and display **FAIL** on the screen, after the problem is resolved, press the **SET / Failure** reset button to remove the warning signal.

As soon as Normal power returns, the AMF-10 verifies this and begins the TDEN (Time Delay Normal to Emergency) countdown showing **【En.XX】** on the screen. Again each entered value equals 5sec, the factory preset TDEN countdown is 10sec (see page 12). When the countdown stops, the module sends a signal to the transfer switch to change-over from emergency to normal power.

Finally the engine executes TDEC. (Time Delay Engine Cool down) The screen display **【CL.XX】** Again each entered value equals to 5sec; the preset TDEC count down is 60sec (see page 12).

**ATTENTION !!**

**When the generator is on Engine Cool-down the AMF-10 protection system remains in effect and if any failure occurs, the module bypasses the countdown and shutdown generator immediately.**

After Engine Cool down, the AMF-10 cuts the Engine fuel by using either one of two different methods (either Energize to Stop or Energize to Start), the AMF-10 display **【SP.XX】** on the front screen.

In AUTO mode, AMF-10 allows the operator to use a remote signal to test the generator With or Without LOAD (programmable). Under no load testing, the AMF-10 starts the genset, but do not test the transfer switch and the generator remains without load. If conducting the test with load, the module starts the genset and using the transfer switch puts the generator on load.

**2.3 Off Mode of Operation**

OFF mode not only serve as shut down of the genset, but also serve as Failure Reset. Under OFF mode, all output functions are disable; this includes the control signal for the transfer (changeover) switch. When switching to **【OFF】** position during the normal genset operation, the module shutdown the genset according to normal shutdown sequence.

If AMF-10 detects a major malfunction during a normal operation, it executes the Emergency Shutdown immediately to prevent further damage to the genset. Once the generator completely stops, the reason for the failure is displayed on the front

panel, helping maintenance locate the problem. To erase the failure signal, press the **【SET / FAILURE Reset】** key or switch to OFF position.

On OFF mode, the operator can press the Increase / Selection **【↵】** button, to get other readings for battery voltage and Operating hours. This readings are switched from one to the other every 2sec.

**2.4 Manual Mode of Operation**

On MANUAL, the operator can manually start and stop the generator and activate the transfer switch to go from Normal to Emergency solely by using the START – STOP - MAINS- GENERATOR buttons on front of the AMF-10

**【START】** Manual Engine Start

**【STOP】** Manual Engine Stop

**【MAIN】** Manually change over to Normal Power

**【GEN】** Manually change over to (Stand by) Power

The Engine Start, Shutdown and transfer switch changeover sequence under MANU mode is the same as the AUTO mode, reference from Section 2.2 (page 7).

**2.5 Test Mode of Operation**

TEST mode is testing function operated under no load from the genset. When switching AMF-10 into TEST mode, if the system with load and under normal power supply status, the module only start up the genset to conduct a test with no load and dismiss the test for the transfer switch changeover.

If the normal power failure occurs during operation of TEST mode, The AMF-10 overwrites the testing operation and automatically carryout the transfer switch changeover to the emergency power on. When the normal power returns, the module continue to supply power from the emergency power supply until the module is switched back to AUTO mode.

### 3. SYSTEM SETTING & OPERATION

**ATTENTION !!**

Before changing factory setting on the AMF-10, make sure all connections are correctly made, (connect the battery last). If you are programming new values to the AMF-10, refer to front panel layout (page 4) and the system programming table on page 13.

#### 3.1 DC Input Supply

The AMF-10 is capable of working with a wide range of input voltages (9VDC to 36VDC) this helps prevent damage to the control from low battery voltage when the engine is cranking.

#### 3.2 System setting (programming)

Changing the settings for the AMF-10 consists of scrolling down through 53 lines of programming and one by one changing each line to the requirement needs for your generator. The operator can input and change the settings by using the buttons on the front panel.

To enter new setting, select OFF, and then hold SET/Failure Reset button down for 4sec.

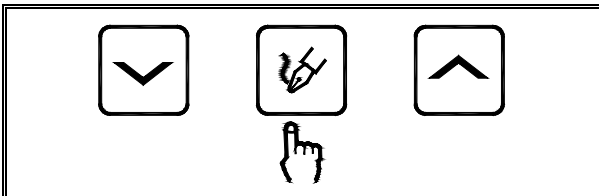

The first thing the screen shows is [ Vr1.0 ] for 2sec, (this is the software version number) after that it changes to [ Pro. ] for Programming, next the display changes to look like the frame underneath.

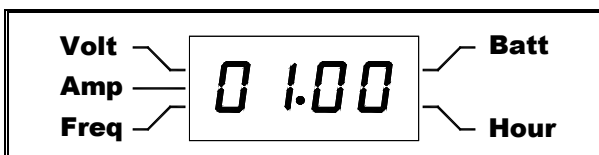

The first 2 digits represent the line number from 01 to 53, the last 2 digits stand the values for that line. You can change the value of the last 2 digits by

using the UP and DOWN arrows following the table on (3.11)

Under System Setting, each time you press the [ Setting ] button, the next line comes up with a complete new set of values. (See Table on page 12), One by one input the settings until all new settings are written. When you reach the last line the panel will say [ End ] this means the settings are completed and memorized by the internal micro processor. You can also END at any time by holding the Setting button for 4sec

To reset the factory setting you need to hold down the [ Down ] [ SET ] [ UP ] buttons ( See below diagram ) together for 4sec until " Au.PO " appears on the screen.

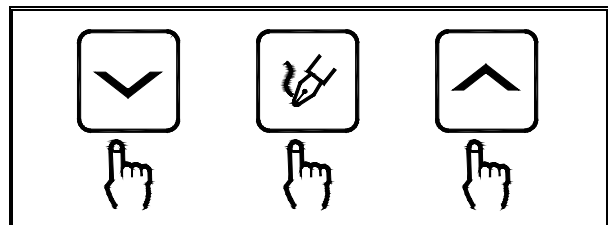

#### 3.3 Operation timer setting

The running hour meter total is stored in the internal memory and cannot be erased or return to zero by either removing the battery or by resetting to factory settings.

If you need to reset the operating hours, follow section 3.2 Enter the System Setting. And before the [ Pro. ] message disappears (you have 4sec), press down [ OFF ] button for 4sec, when the screen shows [ Ch.Hr ] (see the following diagram), this means the AMF-10 is in the operating timer setting.

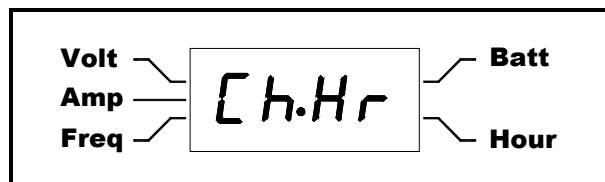

Now you can change the hour-meter by using the UP/DOWN arrows.

### 3.4 AC Voltage & Current Display Setting

The AMF-10 continually monitors normal and generator power displaying these values on the front panel. The AMF-10 monitors full phase voltage, current and frequency (The voltage and current value is calibrated and adjusted at the factory). But if the load has high capacitive or inductive values the waveform distortion may cause the displayed to have small differences from the users measuring instrument.

You can adjust the display value to equal to the users own instruments, by entering the voltage setting mode to perform adjustment and increase or decrease the parameter. Once the adjustment is completed, the 3 phase sensing value increase or decrease according to the adjusted value and display it on the display screen. The AMF-10 over voltage, under voltage and the load current protection follow the adjusted value as the actual system voltage and perform the monitoring according to the new parameter.

See System entry Setting Reference Table lines 6,7,11,12,23,24 for all AC voltage, current display parameter and settings.

### 3.5 Engine Over-Load Protection Setting

**ATTENTION !!**

**AMF-10 provides overload protection from the generator only. There is no overload protection on the normal side.**

To prevent overloading the genset the AMF-10 has an overload protection inputs. It is set according to the generator maximum current output, or any current value below its rated output.

Set the overload protection via the System Setting Lines 26 to 28. Each value equals to 50 ampere. For example: When the number set is 20, the over current value is equals to  $20 * 50A = 1000A$ .

When an engine overload is detected, the AMF-10 overload make sure timer starts and if the over-current condition disappears within the grace period set, the system ignores the incident and resets, but if the overload condition exceeds the preset grace period, the AMF-10 execute the

overload protection and display the overload failure message on the screen, in at the same time perform corresponding overload trip output signal.

AMF-10 provides both warning and system shutdown for overload protection.

- **Overload Shutdown:** When engine overloads, the module immediately stop the engine operation, display failure signal on the panel and in the same time perform corresponding overload trip output signal.
- **Overload Warning:** When engine overloads, the module does not stop the engine, it only display a warning failure signal on the panel, in the same time perform corresponding overload trip output signal. This signal can be used to trip a breaker to make the generator to cool down under no load.

See System Entry Setting Reference Table lines 25, 26, 27, 28 for all overloads protection parameter and settings.

**ATTENTION !!**

**When using the AMF-10 for overload protection, you need to pay special attention not to exceed the CT primary rated current, otherwise the CT will saturation cause incorrect readings leading to a failure in overload protection.**

**For example : CT ratio equals to 1000A : 5A, then over current setting value can not exceed 1000A.**

### 3.6 User Specified Monitoring Setting Alarm1 & Alarm2

The AMF-10 has 2 spare inputs to add two more protections to the system.

See Line entry 44, 45, 46, 47, 48, 49. The two inputs can be setup as a Warning or a shutdown.

### 3.7 Service & Maintenance Setting

The AMF-10 includes a maintenance indicator. When the engine reaches a service interval, the panel displays (Service) advising the staff to carry out scheduled maintenance. When programming service setting, remember that each value represents 10hrs of operating time, for example : when setting value is 20, the timer setting equals to 20 \*10Hr = 200Hr.

Once maintenance is finished, go to line 53 to reset the service timer back to **【0】** .

Refer to System Setting Table Lines 52, 53 for Service and maintenance setting and related information.

### 3.8 Digital display setting

The AMF-10 display can be set to fix or cycling. (Line 51) In cycling the AMF-10 take turns displaying in sequence Volts, Amps, Hz on the screen for 2sec. To read Operating hours and Battery Voltage you must override the display by using the increase **【↗】** the **【SET】** button to select readings of L12 \ L23 and L31 phase, and decrease **【↘】** button to see battery voltage and operating hour.

When a specific parameter is selected, the cycling display pauses and display the selected parameter for 30sec, after 30sec the system resumes the cycling parameter display.

See System Setting Reference Table entry (Line 51) for display type setting and related information.

### 3.9 Engine Idle

To prevent operating the engine at full speed immediately after starting and give it time to heat up, the AMF-10 can operate the engine in idle mode, allowing the genset to warm up. The operator can define the time on idle according to onsite and climate requirements.

Go to the System Setting Reference Table (Line 05) for Engine idle operation function setting and related information.

This is only possible if the Genset has an electrical governor control.

### 3.10 Automatic Transferring Switch (ATS) function

When the AMF-10 is in AUTO, the module monitors street power. If any voltage abnormality or open phase is detected, the module sends a start signal to the genset in order to start the engine and provide continual power supply to the load.

AMF-10 has 2 electrical interlock control signals TDNE (Time Delay Normal to Emergency) and TDEN (Time Delay Emergency to Normal), The system control sequence first disconnect with time delay then engage, to ensure Transfer Switch not engage normal power supply and emergency power supply at the same time.

Go to the System Setting Reference Table lines 02 and 03, for ATS (Automatic Transfer Switch) for setting information.

### 3.11 Communication with PC (KCU-XX)

GCU-100 with optional USB / RS485 / Ethernet remote communication functions. User can easy read all the real time information and remote control the local device via communication interface modules. There are 3 different purpose interface modules show as below :

KCU-01 – USB interface module.

KCU-02 – RS-485 interface module.

KCU-03 – Ethernet interface module.

For remote communication settings please refer to system setting reference table entries **【54】** \ **【55】** and **【56】** .

When the item **【54】** set to 00, then user can read all the real time information from the controller only. But when it set to 01, it allow remote control from PC also.

The items **【55】** and **【56】** is for KCU-02 RS485 interface module used only, others don't care.

For detail information please refer to the KCU-XX user manual.

**NOTE !!**

**When use the KCU-02 to make a closed LAN, Different controller address setting must be different and the Baud rate setting must be the same.**

### 3.12 System Setting Reference Table

| ITEM | DESCRIPTION   | SETTING   | FACTORY SETTING |
|------|---|---|-----------------|
| 1    | Phase selection (3Ø3W 1Ø3W or 1Ø)   | 00 → 3Ø3W 01 → 1Ø3W 02 → 1Ø                           | 00              |
| 2    | TDEN Time Delay Emergency to Normal<br>Each enter value equals to 5sec<br>For example If you enter 5, the delay time is equal to 25sec (5*5sec = 25sec) | 0 ~ 60 ( 0 ~ 300sec )                                 | 2 (10sec)       |
| 3    | TDNE Time Delay Normal to Emergency<br>Each enter value equals to 5sec<br>For example if you enter 5, the delay time is equal to 25sec (5*5sec = 25sec) | 0 ~ 60 ( 0 ~ 300sec )                                 | 2 (10sec)       |
| 4    | TDEC Time Delay Engine Cooling<br>Each enter value equals to 5sec<br>For example if you enter 5, the delay time is equal to 25sec (5*5sec = 25sec)      | 0 ~ 60 ( 0 ~ 300sec )                                 | 12 (60sec)      |
| 5    | Engine idle time delay setting<br>Each enter value equals to 5sec<br>For example if you enter 5, the delay time is equal to 25sec (5*5sec = 25sec)      | 0 ~ 60 ( 0 ~ 300sec )                                 | 00              |
| 6    | Normal power voltage display function setting   | 00 → Tune Up 01 → Tune Down                           | 00              |
| 7    | Normal power voltage display adjustment setting   | 00~ 99 V  | 00              |
| 8    | Normal power over voltage setting   | 11 ~ 50 ( 110V ~500V )                                | 25 (250V)       |
| 9    | Normal power under voltage setting  | 08 ~ 47 ( 80V ~ 470V )                                | 18 (180V)       |
| 10   | Normal power voltage abnormality validating time setting  | 2 ~ 99sec   | 10sec           |
| 11   | Emergency power voltage display function setting  | 00 → Tune Up 01 → Tune Down                           | 00              |
| 12   | Emergency power voltage display adjustment setting  | 00~ 99 V  | 00              |
| 13   | Emergency power over voltage setting  | 11 ~ 50 ( 110V ~500V )                                | 25 (250V)       |
| 14   | Emergency power under voltage setting   | 08 ~ 47 ( 80V ~ 470V )                                | 18 (180V)       |
| 15   | Emergency power voltage abnormality validating time setting   | 0 ~ 99sec<br>(0 Emergency Voltage detection disabled) | 10              |
| 16   | Emergency power voltage abnormality execution   | 00 → Warning 01 → Engine stop                         | 01              |
| 17   | Engine over speed set point   | 51 ~ 75HZ   | 65HZ            |
| 18   | Engine over speed validating time setting   | 00 ~ 99 sec<br>(0 – Engine Over Speed disabled)       | 05              |
| 19   | Engine under speed set point  | 40 ~59HZ  | 55HZ            |
| 20   | Engine under speed validating time setting  | 00 ~ 99 sec<br>(0 – Engine Under Speed disabled)      | 05              |
| 21   | Engine under speed execution  | 00 → Warning 01 → Engine Stop                         | 01              |
| 22   | Current Transformer (CT) installed position   | 00 → Load 01 → Normal<br>02 → Emergency               | 00              |
| 23   | AC current display function setting   | 00 → Tune Up 01 → Tune Down                           | 00              |
| 24   | AC current display adjustment setting   | 00~ 99 A  | 00 A            |

| ITEM | DESCRIPTION  | SETTING  |   |  | FACTORY SETTING     |
|------|--|--|---|--|---------------------|
| 25   | Rated Current Transformer (CT) ampere setting<br>For example: default value set to 5 = 100A/5A current transformer (CT) is selected<br>(When external rated current transformer rating and setting differs from the specified, the current readings may become inaccurate) | 1 ( 25/5)<br>4 ( 75/5)<br>7 ( 200/5)<br>10 ( 400/5)<br>13 ( 750/5)<br>16 ( 1200/5)<br>19 ( 2000/5) | 2 ( 50/5)<br>5 ( 100/5)<br>8 ( 250/5)<br>11 ( 500/5)<br>14 ( 800/5)<br>17 ( 1500/5)<br>20 ( 3000/5) | 3 ( 60/5)<br>6 ( 150/5)<br>9 ( 300/5)<br>12 ( 600/5)<br>15 ( 1000/5)<br>18 ( 1600/5) | <b>05</b>           |
| 26   | Overload protection setting. (every defined value represents 50 ampere)<br>For example : enter value 20, this means the over current activation value is set to 20 * 50A=1000A   | 1 ~ 60 (50 ~ 3000A)  |   |  | <b>2<br/>(100A)</b> |
| 27   | Engine overload activation delay time  | 00 ~ 99sec<br>(0 = Disable overload warning)   |   |  | <b>0</b>            |
| 28   | Set engine overload protection as warning or engine stop   | 00 → Warning    01 → Engine stop   |   |  | <b>00</b>           |
| 29   | Oil pressure switch as NO or NC  | 00 → NO    01 → NC   |   |  | <b>01</b>           |
| 30   | Low oil pressure warning confirmation time   | 02 ~ 99 sec  |   |  | <b>05</b>           |
| 31   | Set high water temperature switch NO or NC   | 00 → NO    01 → NC   |   |  | <b>00</b>           |
| 32   | High water temperature activation delay time   | 02 ~ 99 sec  |   |  | <b>05</b>           |
| 33   | Fuel level switch as NO or NC  | 00 ( No fuel level switch)<br>01 → NO    02 → NC   |   |  | <b>00</b>           |
| 34   | Low fuel level activation delay time   | 02 ~ 99 sec  |   |  | <b>10</b>           |
| 35   | Set low fuel level as Warning or Engine stop   | 00 → Warning    01 → Engine stop   |   |  | <b>00</b>           |
| 36   | Battery under voltage setting  | 08 ~ 23 VDC  |   |  | <b>08 VDC</b>       |
| 37   | Battery over voltage setting   | 13 ~ 35 VDC  |   |  | <b>32 VDC</b>       |
| 38   | Engine preheat time setting  | 00 ~ 99 sec  |   |  | <b>06</b>           |
| 39   | Attempts permitted to restart engine   | 01 ~ 09  |   |  | <b>03</b>           |
| 40   | Starter motor crank time setting   | 02 ~ 30 sec  |   |  | <b>06</b>           |
| 41   | Oil pressure switch selected to check and permit engine start  | 00 → NO    01 → YES  |   |  | <b>01</b>           |
| 42   | Engine Stop Time Setting   | 02 ~ 99 sec  |   |  | <b>10</b>           |
| 43   | Engine Stop (Energize to stop or energize to start)  | 00 (Energize to stop)<br>01 (Energize to start)  |   |  | <b>00</b>           |
| 44   | User defined Alarm1 as NO or NC type   | 00 → No Alarm1 input signal<br>01 → NO    02 → NC  |   |  | <b>00</b>           |
| 45   | Set Alarm1 time configuration  | 02 ~ 99 sec  |   |  | <b>10</b>           |
| 46   | Set Alarm1 signal as Warning or Engine stop  | 00 → Warning    01 → Engine stop   |   |  | <b>00</b>           |
| 47   | User defined Alarm2 as NO or NC type   | 00 → No Alarm2 input signal<br>01 → NO    02 → NC  |   |  | <b>00</b>           |
| 48   | Set Alarm2 time configuration  | 02 ~ 99 sec  |   |  | <b>10</b>           |
| 49   | Set Alarm2 signal as Warning or Engine stop  | 00 → Warning    01 → Engine stop   |   |  | <b>00</b>           |
| 50   | External remote testing with load or without load  | 00 → With load    01 → Without load  |   |  | <b>01</b>           |
| 51   | Display Type   | 00 → Fixed display<br>01 → Cycling display   |   |  | <b>01</b>           |
| 52   | Engine Service & Maintenance warning (Each input value = 10 hours)   | 00 ~ 25 (0 ~ 250Hours)<br>(0 = Disable service & maintenance warning)                              |   |  | <b>00</b>           |
| 53   | Reset Service & Maintenance warning timer  | 00 → YES    01 → NO  |   |  | <b>01</b>           |

---















|    |  |   |  |           |
|----|--|---|--|-----------|
| 54 | Enable remote control by KCU-xx Module | 00 → NO   | 01 → Yes   | <b>00</b> |
| 55 | KCU-02 module address setting          | 00 → None<br>01 ~ 99  |  | <b>00</b> |
| 56 | KCU-02 Baud rate setting               | 01 → 115200<br>03 → 38400<br>05 → 14400<br>07 → 4800<br>09 → 1200 | 02 → 57600<br>04 → 19200<br>06 → 9600<br>08 → 2400 | <b>03</b> |

## 4. SYSTEM WARNING & FAILURE DESCRIPTION

### 4.1 Failure Symbol Reference Table

AMF-10 has a 7 segment display screen in addition to individual LED graphic indicators showing the operator of all operating status.

**Icon Reference Table**

| WARNING SIGNAL  | DESCRIPTION                   | EXECUTION           |
|---|-------------------------------|---------------------|
|    | Engine Start Failure          | Shutdown            |
|    | Emergency Shutdown Activated  | Shutdown            |
|    | High Water Temperature        | Shutdown            |
|    | Low Oil Pressure              | Shutdown            |
|   | Over-speed                    | Shutdown            |
|  | Under-speed                   | Shutdown or Warning |
|  | AC over voltage               | Shutdown or Warning |
|  | AC under voltage              | Shutdown or Warning |
|  | Genset Over-load              | Shutdown or Warning |
|  | Low Fuel Level                | Shutdown or Warning |
|  | Low Battery Voltage Warning   | Warning             |
|  | Service & Maintenance Warning | Warning             |
|  | Spare Setting 1               | Shutdown or Warning |
|  | Spare Setting 2               | Shutdown or Warning |
|  | Normal Power available        |                     |

### 4.2 Warning Mode

If the AMF-10 detects a fault and this fault is a minor problem the AMF-10 gives you a warning. If the fault is hazardous to the engine or generator, it shutdown

immediately depending how it has initially setup If it is a warning the genset continue to work, but all the warning signals remain illuminated on the front panel and continue to be displayed until repaired.

### 4.3 Shutdown Mode

If the AMF-10 detects a mayor problem on the generator the module executes an Emergency Shutdown, showing the reason for the failure, and guiding the maintenance staff to perform repairs, and after all failures are fixed, switch to [ OFF ] OFF mode or hold [ SETTING / Failure Reset ] button (key) to erase the failure signal, restart the genset and load test and see if the problems are eliminated.

## 5. SPECIFICATION

| ITEM                                  | SPECIFICATION        |
|---------------------------------------|----------------------|
| DC Supply                             | 9 ~ 36 VDC           |
| Alternator Input Range                | 15 ~ 510 VAC (Ph-Ph) |
| Alternator Input Frequency            | 50 ~ 60 Hz           |
| Start Signal Output                   | 10 Amp @ 12/24VDC    |
| Fuel Solenoid Signal Output           | 10 Amp @ 12/24VDC    |
| Preheat Signal Output                 | 10 Amp @ 12/24VDC    |
| Accessory "ON" Output                 | 10 Amp @ 12/24VDC    |
| Idle Control Conductor Capacity       | 10 Amp @ 12/24VDC    |
| Warning Signal Output                 | 10 Amp @ 12/24VDC    |
| Overload Alarm Output                 | 10 Amp @ 12/24VDC    |
| Normal Power Connect to Load Signal   | 8 Amp @ 250VAC       |
| Stand by Power Connect to Load Signal | 8 Amp @ 250VAC       |
| Power Consumption                     | Under 5VA            |
| Operating Temperature                 | -20 to 70°C          |
| Relative Humidity                     | Under 95%            |
| Rated CT Capacity                     | Above 2.5VA          |
| Secondary Rated current               | 5A                   |
| Weight                                | 0.5KG                |

## 6. TERMINAL & WIRING DESCRIPTION

### 6.1 Connection Detail

| PIN No. | DESCRIPTION                               | ATTENTION   |
|---------|---|---|
| J1-1    | Null                                      | Spare   |
| J1-2    | Battery negative (-V)                     | System DC negative input. (Battery Negative).                     |
| J1-3    | Battery positive (+V)                     | System DC positive input. (Battery Positive).                     |
| J1-4    | Alarm signal Output                       | Used to control external alarm buzzer. Supply (+V) 8 Amp rated    |
| J1-5    | Idle control signal output                | Connect to Governor Idle control. Supply (+V) 8 Amp rated         |
| J1-6    | Starter motor Signal Output               | Connect to Starter Motor. Supply (+V) 8 Amp                       |
| J1-7    | Fuel Solenoid Signal Output               | Connect to Fuel Solenoid or Fuel Valve Control. Supply (+V) 8 Amp |
| J1-8    | Accessory "ON" Output                     | Connect to the panel lamp. Supply (+V) 8 Amp                      |
| J1-9    | Overload alarm signal output              | Used to trip the AC output breaker. Supply (+V) 8 Amp             |
| J1-10   | Pre-heat Signal Output                    | Used to control the internal Heater. Supply (+V) 8 Amp            |
| J1-11   | Emergency Stop Signal Input               | Connect to external emergency stop switch                         |
| J1-12   | Temperature Switch Input                  | Connect to Temperature Switch                                     |
| J1-13   | Oil Pressure Switch Input                 | Connect to Oil Pressure Switch                                    |
| J1-14   | Fuel Level Switch input                   | Connect to Fuel Level Switch                                      |
| J1-15   | Spare1 / User Define Warning Signal Input | Negative input When Action  |
| J1-16   | Spare2 / User Define Warning Signal Input | Negative input When Action  |
| J1-17   | Remote Start Signal Input                 | Connect to external remote test switch                            |
| J1-18   | Null                                      | spare   |
| J2-1    | Normal L1 sensing input.                  | Connect to the Normal power phase L1                              |
| J2-2    | Normal L2 sensing input.                  | Connect to the Normal power phase L2                              |
| J2-3    | Normal L3 sensing input.                  | Connect to the Normal power phase L3                              |
| J3-1    | Normal "ON" signal output                 | Connect to normal "ON" Coil. Supply 8 Amp                         |
| J3-2    | Normal "ON" signal output                 | Connect to normal "ON" Coil. Supply 8 Amp                         |
| J3-3    | Emergency "ON" signal output              | Connect to Emergency "ON" Coil. Supply 8 Amp                      |
| J3-4    | Emergency "ON" signal output              | Connect to Emergency "ON" Coil. Supply 8 Amp                      |
| J3-5    | Normal "ON" feedback signal input         | Connect normal "ON" feedback switch                               |
| J3-6    | Emergency "ON" feedback signal input      | Connect Emergency "ON" feedback switch                            |
| J3-7    | CT comm. terminal input                   | Connect to external CTs common position                           |
| J3-8    | CT secondary for L1                       | Connect to secondary of L1 monitoring CT                          |
| J3-9    | CT secondary for L2                       | Connect to secondary of L2 monitoring CT                          |
| J3-10   | CT secondary for L3                       | Connect to secondary of L3 monitoring CT                          |
| J4-1    | Emergency L1 sensing input.               | Connect to the genset power phase L1                              |
| J4-2    | Emergency L2 sensing input.               | Connect to the genset power phase L2                              |
| J4-3    | Emergency L3 sensing input.               | Connect to the genset power phase L3                              |

## 6.2 Wiring Diagram

### 6.2.1 3 Phase 4 Wires Wiring Diagram

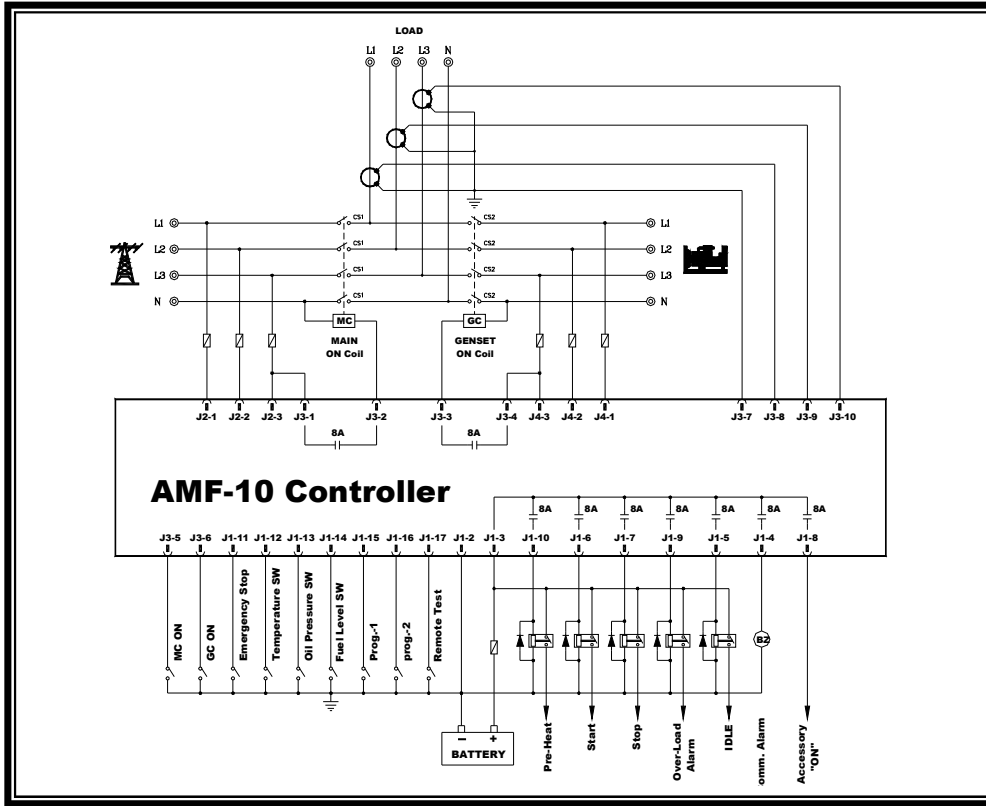

### 6.2.2 3 Phase 3 Wires Wiring Diagram

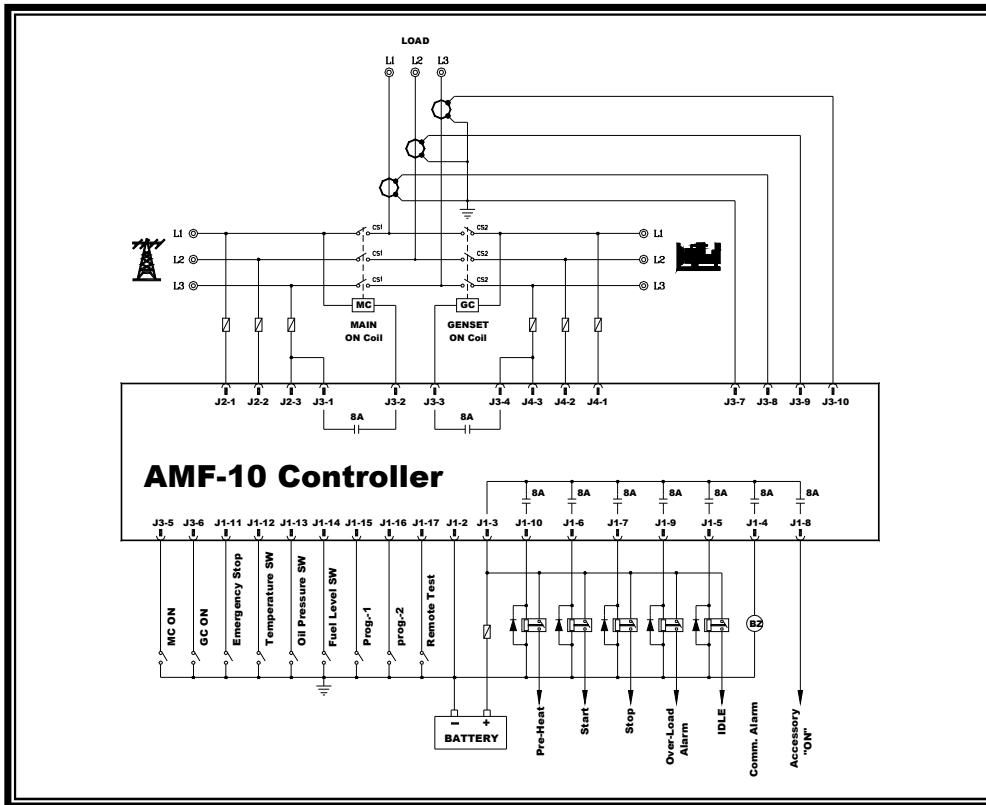

### 6.2.3 Single Phase 3 Wires Wiring Diagram

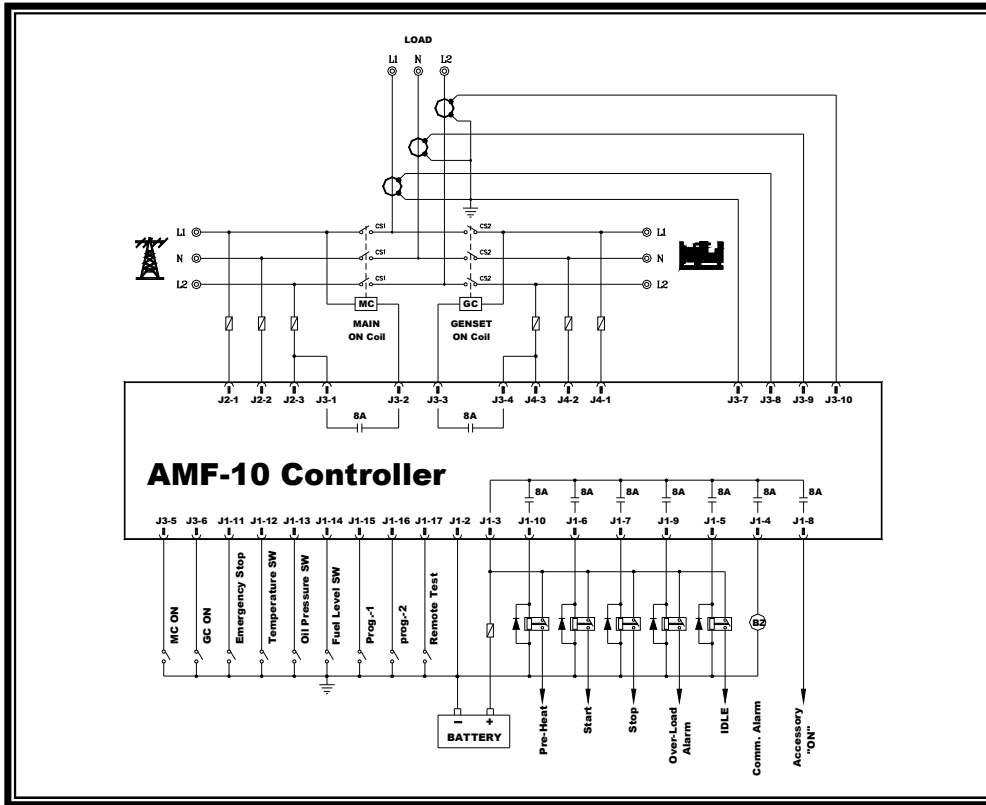

### 6.2.4 Single Phase Wiring Diagram

