

DSP-30

Percentage Power Meter Display Module





Front Panel Display

DSP-30 Display panel has three four Digits bright LED's that shows (RMS) Voltage, Amps and percentage of full Power. The user can easily read the real time 3 phase Voltage, Amps and the percent of power that load is using now.

Programming Mode

There are three push buttons on the front panel for 100% full power range setting. User need to set the full power range in KVA before used. The buttons function description show as below.

-  **Program key** : Press it will into program mode.
-  **Up key** : Press it will increase the setting value.
-  **Down key** : Press it will decrease the setting value.

How to Program the DSP-30 (1KVA / Unit)

- Step-1** : Press the program key for 2 seconds and then the DSP-30 will into program mode and the screen show as below.
- Step-2** : Use Up or Down key for 100% power range setting.
- Step-3** : Press program key again to exit the program mode.



Display Function

The operator can change the voltage and current display to be fixed or cycling from phase to phase by simply using the button next to each display.

To change the display mode, press the button next to it. See diagram.

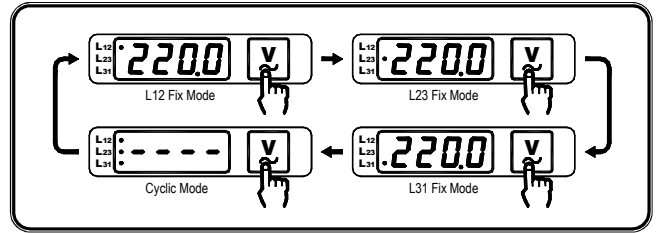

Rear Panel Layout



Recommended Cut-Out : 66 * 66 ± 0.5 mm

Voltage and Current Adjustment (If Need)

In the back of the DSP-10 module we have 4 push buttons for voltage [V↑ & V↓] and current [A↑ & A↓] adjustment. The Module comes factory tested and calibrated and normally no changes are necessary. But if any modifications are required, follow the procedures below.

Voltage Adjustment

(Please use and accurate RMS Voltmeter as your reference)

- Start the generator. Set your reference AC voltage using your Voltmeter.
- Select the desire phase you need to re-calibrate using the front display [V] button on the display and hold.
- Repeatedly press [V↑] or [V↓] on back of module to adjust the displayed voltage equivalent to your voltmeter.
- Release the front [V] button. The LED display will flash continuously for 5 seconds.
- After for 5 seconds then the system will automatically record the new setting and return to normal.
- If the display shows [FAIL] the setting is invalid, and step 3 must be repeated.

Current Adjustment Procedure

(Please use Standard RMS Current meter for readings)

- Set the dip switches to the correct [CT] in use.
- Start the generator. And wait for the generator to stabilize.
- Slowly add load to the genset until maximum rated load current is reached for the CT in use.
- Select desire phase current to calibrate using the front [A] button.
- Repeatedly press [A↑] or [A↓] on the back panel to adjusts the displayed current to its equivalent on the current meter.
- Release the front [A] button. The LED on the display will flash continuously for 5 seconds.
- After 5 seconds the system will automatically record the new setting and return to normal.
- If the panel display shows [FAIL] then the previous setting is invalid, please return to step 5.



固也泰電子工業有限公司
KUTAI ELECTRONICS INDUSTRY CO., LTD.



Setting The CT Value

Set the 5 pin dip switch for the CT (Current Transformer) and the system phase you are using.

Dip Switch Setting Reference Diagram

Current Transformer (CT) Programmer Table		<input type="checkbox"/> =ON	<input type="checkbox"/> =OFF
<input type="checkbox"/> <input type="checkbox"/> <input type="checkbox"/> <input type="checkbox"/> 50/5A	<input type="checkbox"/> <input type="checkbox"/> <input type="checkbox"/> <input type="checkbox"/> 250/5A	<input type="checkbox"/> <input type="checkbox"/> <input type="checkbox"/> <input type="checkbox"/> 600/5A	<input type="checkbox"/> <input type="checkbox"/> <input type="checkbox"/> <input type="checkbox"/> 1500/5A
<input type="checkbox"/> <input type="checkbox"/> <input type="checkbox"/> <input type="checkbox"/> 100/5A	<input type="checkbox"/> <input type="checkbox"/> <input type="checkbox"/> <input type="checkbox"/> 300/5A	<input type="checkbox"/> <input type="checkbox"/> <input type="checkbox"/> <input type="checkbox"/> 800/5A	<input type="checkbox"/> <input type="checkbox"/> <input type="checkbox"/> <input type="checkbox"/> 1600/5A
<input type="checkbox"/> <input type="checkbox"/> <input type="checkbox"/> <input type="checkbox"/> 150/5A	<input type="checkbox"/> <input type="checkbox"/> <input type="checkbox"/> <input type="checkbox"/> 400/5A	<input type="checkbox"/> <input type="checkbox"/> <input type="checkbox"/> <input type="checkbox"/> 1000/5A	<input type="checkbox"/> <input type="checkbox"/> <input type="checkbox"/> <input type="checkbox"/> 2000/5A
<input type="checkbox"/> <input type="checkbox"/> <input type="checkbox"/> <input type="checkbox"/> 200/5A	<input type="checkbox"/> <input type="checkbox"/> <input type="checkbox"/> <input type="checkbox"/> 500/5A	<input type="checkbox"/> <input type="checkbox"/> <input type="checkbox"/> <input type="checkbox"/> 1200/5A	<input type="checkbox"/> <input type="checkbox"/> <input type="checkbox"/> <input type="checkbox"/> 3000/5A
System Phase select		<input type="checkbox"/> = 3 Phase	<input type="checkbox"/> = 1 Phase

Specification

ITEM	DESCRIPTION
DC Supply	9.0 ~ 36 V
Alternator Input Range	10 ~ 500VAC(Ph-Ph)
Alternator Input Frequency	50/60 Hz
CT Burden	Above 2.5VA
CT Secondary	5A
Max. CT Rated	3000A / 5A
Operating Temperature	-20 °C to +70 °C
Relative Humidity	90% or Below
Power Consumption	Under 2W
Weight	200 gram

Three Phase System Standard Wiring Diagram

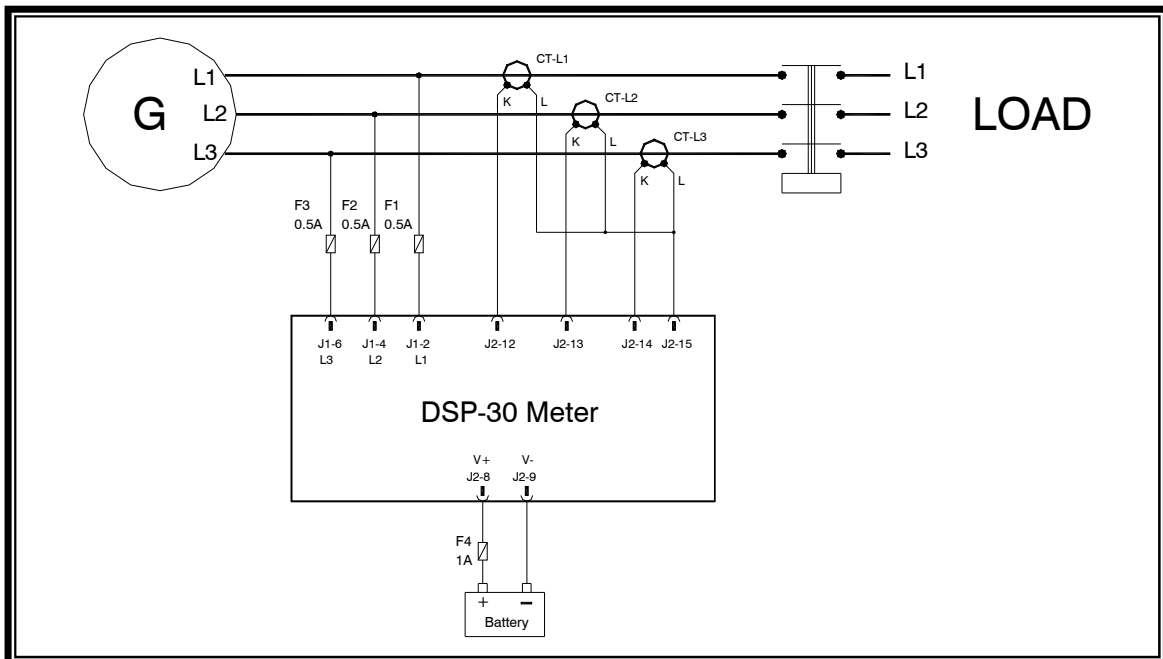

Single Phase System Standard Wiring Diagram

