

GCU-30

Manual Key Start Genset Control and Protection Module

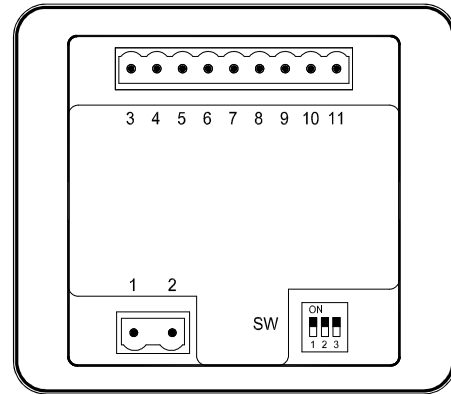

Rear Panel Layout



Suggested Panel Opening : 66 * 66 ± 0.5 mm

GCU-30 is a manual key start genset control and protection module suitable for most available genset on the market.

System Protection

Description of each protection, condition and manners :

- **High Engine Temperature Protection :**
Failure confirmation delay [3sec]
Temperature Switch type [Normal Open NO.]
- **Low Oil Pressure Protection :**
Failure confirmation delay [3sec]
Oil Pressure Switch type [Normal Close NC.]
- **Engine Over Speed Protection :**
Failure confirmation delay [3sec]
50Hz [Activate @ 55Hz] : 60Hz [Activate @ 66Hz]
- **User Define Protection :**
Failure confirmation delay [2sec]
Input contact type [Normal Open NO.]
- **Charge Alternator Failure :**
Failure confirmation delay [3sec]
Warning activated when Charge voltage is below Battery 5VDC

Warning Icon Reference Table

| ICON | DESCRIPTION | ACTION |
|------|---------------------------|----------|
| | Engine Running | None |
| | Over-speed | Shutdown |
| | Low Engine Oil Pressure | Shutdown |
| | High Water Temperature | Shutdown |
| | Spare Shutdown | Shutdown |
| | Charge Alternator Failure | Warning |

System Setting

GCU-30 is equipped with a 3P dip switch for system setting. User should select the correct setting to comply with the system specification

- SW 1 : AC Frequency [ON : 50Hz OFF : 60Hz]
- SW 2 : Engine Stop Mode
[ON : Energized to Start OFF : Energized to Stop]
- SW 3 : Engine Stop Timer Delay
[ON : 20 sec OFF : 10 sec]

After wiring is completed, user should always check and adjust the system setting accordingly to prevent engine from failing to operate.

Specification

| ITEM | DESCRIPTION |
|---------------------------------------|--------------------|
| Rated DC Input Voltage | 9.0 to 36 V |
| Rated AC Input Voltage | 5 ~ 500VAC |
| AC Frequency | 50/60 Hz |
| Engine Stop Signal Output | 1.2 Amp @ 12/24VDC |
| Engine Start Signal Output | 1.2 Amp @ 12/24VDC |
| Preheat Signal Output | 1.2 Amp @ 12/24VDC |
| Charge Motor Excitation Signal Output | 12/24VDC |
| Operation Temperature | -20 °C to +70 °C |
| Relative Humidity | 90% or Below |
| Rated Dissipation | Under 3VA |
| Weight | 150gram |



固也泰電子工業有限公司
KUTAI ELECTRONICS CO., LTD.



MANU Operation

To initiate a start sequence turn key to Manual [Manu] position and follow the below steps.

First, Press [Pre-Heat] button when needed, the Engine Operating LED shall illuminate and flash. The pre-heat time is governed by continual holding of the [Pre-Heat] button, once button is released the pre-heat process is immediately terminated.

Second, Press [Start] button, the starter motor will begin to crank. Release the [Start] button when engine is successfully fired. The starter motor crank cycle is governed by continual holding of the [Start] button, once button is released the starter motor will immediately disengage.

Should GCU-30 operate is determine by the below two conditions, when either one condition is established the module will automatically disengage the starter motor to prevent damage caused by the high revving engine operation.

- [Start] button released
- AC Frequency 18Hz and above is established

Once the engine is successfully fired, the module will cancel all protection operations except for User Defined Protection for 20 seconds to enable the engine to build up to the rated operation condition.

OFF Operation

The [OFF] position places the module into its Stop or Reset mode. If the key switch is turned to [OFF] position during operation, the generator will execute engine stop according to the dip switch setting of SW3 Engine Stop Timer Delay.

Under [OFF] operation, the module will automatically cancel the operation of [Start] & [Pre-Heat] button.

If a failure is detected during operation, GCU-30 will execute engine stop immediately to prevent further damage or loss. The specific failure warning notice LED will be illuminated once the engine comes to a complete stop and the maintenance personnel can proceed necessary repairing accordingly. To reset the warning notice switch the key switch to [OFF] position.

Warning!!

Warning 1 :

If engine Pre-Heat is required during the firing of engine, user can press [Start] & [Pre-Heat] button at the same time. The Engine Operation LED will illuminate and flash to warning the user.

Warning 2 :

If engine do not correctly fire after releasing the [Start] button, please turn key switch to [OFF] position and then back to [Manu] to reengage engine start.

Standard Wiring Diagram

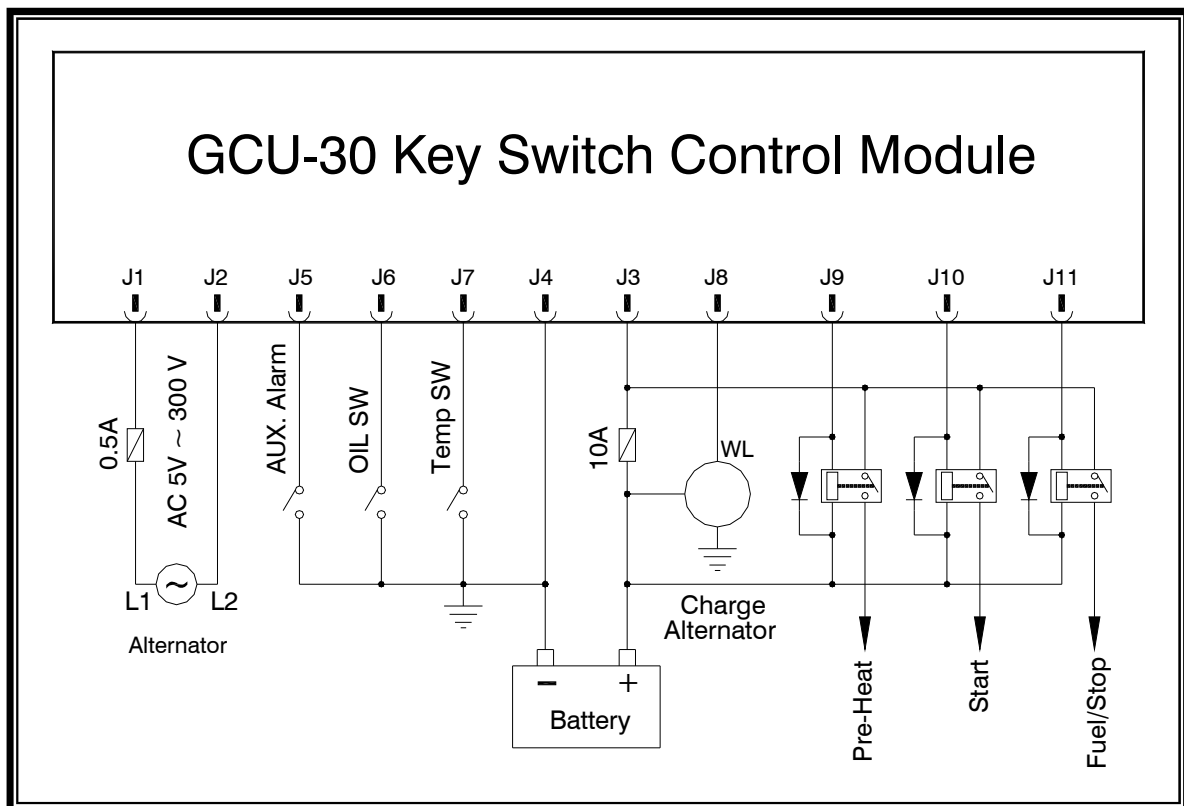

lease link to <http://www.kutai.com.tw> for detailed manual