

# PS-01

## Ceramic Capacitive Oil Pressure Sensor

Exclusive accessory for GCU-2000 / GCU-3000 Digital Genset PLC Control Unit

### Features

- Full Scale Accuracy  $\pm 2.5\%$  (0~120 Psi)
- Operating Temperature Range -40~140 °C
- EMI Protection to 100 V/m
- Transmission Distance Max. 30M
- Waterproof Integral Electrical Connector
- Exceptional Shake and Vibration Tolerance
- No Adjustment Needed, 100% Compatibility if New Sensor Replaced
- Ceramic Capacitive Pressure Sensor, Excellent Accuracy, More Precise Than The Traditional Resistance Pressure Sensor
- Built in Temperature Compensatory, Excellent Stability, Unaffected from External Thermal Interference
- Extremely Stable Linearity Output, No need for Adjustment After Installation or Maintenance



### Specifications

<b>Supply Voltage</b>	4.5~5.5 VDC	<b>Operating Pressure</b>	0~120 Psi (0~8.0 Bar)
<b>Output Voltage</b>	0.5~4.5 VDC	<b>Proof Pressure</b>	230 Psi (16.0 Bar)
<b>Supply Current</b>	10 mA at 5.5V	<b>Burst Pressure</b>	435 Psi (30.0 Bar)
<b>Output Current</b>	1.5 mA	<b>Thread</b>	1/8-27 NPTF-2A
<b>Output Ripple</b>	25 mV rms	<b>Ingress Protection</b>	IP65
<b>Accuracy</b>	$\pm 2.5\%$ (0~120 Psi)	<b>Operating Temperature</b>	-40~140 °C
<b>Thermal Effect on Snap</b>	$\pm 0.002\% / ^\circ\text{C}$		

### Mechanical Specifications (Unit : mm)

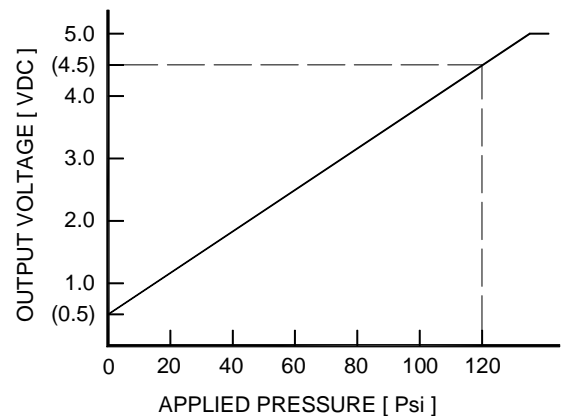
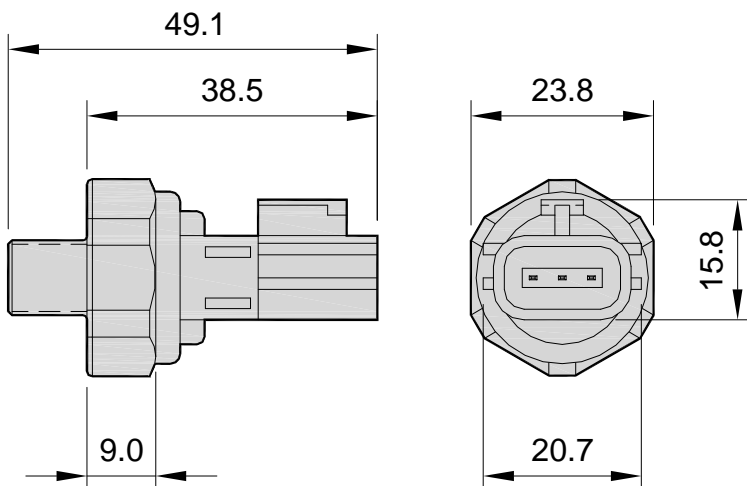

### Physical Specification

<b>Dimensions</b>	PS-01-2.5	2.5M	<b>Weight</b>	PS-01-2.5	141 g $\pm 2\%$
	PS-01-5.0	5.0M		PS-01-5.0	231 g $\pm 2\%$