

ADVR-083-400HZ

Universal Hybrid Analog-Digital Voltage Regulator Operation Manual

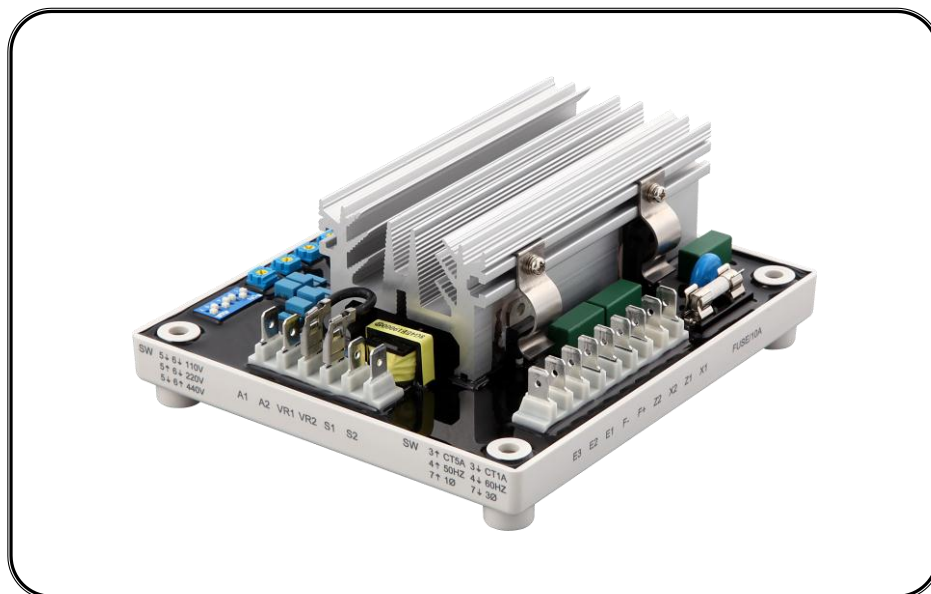

Universal 400Hz Intermediate Frequency
Analog / Digital AVR, Single-phase / Three-phase Sensing
8 Amp Voltage Regulator for use with Auxiliary Winding, PMG, and
self-excited (SHUNT) brushless generators.

For Aviation and Military Spec 400Hz Generators



KUTAI ELECTRONICS INDUSTRY CO., LTD.

TEL : +886-7-8121771

FAX : +886-7-8121775

Website : www.kutai.com.tw

Headquarters : No.3, Ln. 201, Qianfu St., Qianzhen Dist., Kaohsiung City 806037, Taiwan



SECTION 1 : SPECIFICATION

Sensing Input (E1, E2, E3) Average Reading

Voltage and Frequency DIP switch settings

1 phase (E1, E2) / 3 phase (E1, E2, E3)

90 – 130 Vac @ 110 Vac

180 – 260 Vac @ 220 Vac

340 – 520 Vac @ 440 Vac

Frequency 320 – 420 Hz

Power Input (X1, X2, Z2)

Voltage 60 – 300 Vac, 1 phase / 3 phase

1 phase (X1, X2) / 3 phase (X1, X2, Z2)

Frequency 40 – 500 Hz

Auxiliary Input (Z1, Z2)

Voltage 60 – 300 Vac, 1 phase 2 wire

Frequency 40 – 500 Hz

Excitation Output (F+, F-)

110V 1 phase Continuous 63 Vdc 8A
Max. 90 Vdc 10A for 10 secs.

220V 1 phase Continuous 125 Vdc 8A
Max. 180 Vdc 10A for 10 secs.

220V 3 phase Continuous 150 Vdc 8A
Max. 215 Vdc 10A for 10 secs.

Resistance Min.15 ohms, Max.100 ohms @ 220V

Fuse Spec. Slow blow 5 x 20 mm 10A

External Voltage Adjustment (VR1, VR2)

Max. +/- 10% @ 1K ohm 1 watt potentiometer

Quadrature Droop Input (S1, S2)

CT N:5A or N:1A (DIP switch setting)

Burden : greater than 5VA

Sensitivity +/- 7% @ PF +/- 0.5

(Can be adjusted through Droop setting)

Analogue Voltage Input (A1, A2)

Input resistance greater than 2K ohms

Input Range +/- 5 Vdc or 0 – 10 Vdc

Sensitivity Max.1 Vdc = 5% change in output voltage

(Can be adjusted through Trim setting)

Build Up Voltage

Greater than 5 Vac, 25 Hz residual volts input power

Soft Start Ramp Time

4 seconds +/- 10%

Voltage Regulation

Less than +/- 0.5% (with 4% engine governing)

Typical System Response

Less than 20 milliseconds

EMI

Built-in Harmonic suppression

Static Power Dissipation

Max. 6 watts

Under Frequency Protection (Factory Preset)

400 Hz system preset knee point at 360 Hz

Over Excitation Protection

25 – 105% of Input Power (adjust with OE pot.)

O/E acts after 10 sec. delay. The OE function can be turned OFF by adjusting OE. clockwise to max.

Voltage Thermal Drift

Less than 3% from -40 to +70 °C

Under-Frequency Knee Point Thermal Drift

Less than +/- 0.1 Hz from -40 to +70 °C

Environment

Operation Temperature -40 to +60 °C

Storage Temperature -40 to +85 °C

Relative Humidity Max. 95%

Vibration 5.5Gs @ 60 Hz

Dimensions

150.0 (L) x 135.0 (W) x 61.0 (H) mm

5.91 (L) x 5.31 (W) x 2.40 (H) inch

Weight

750 g +/- 2%

1.654 lb +/- 2%

ATTENTION

In order to avoid permanent damage to the AVR confirm that the voltage sensing input setting matches the generator before use (DIP switches SW5 and SW6)

SECTION 2 : OUTLINE / SIZE / INSTALLATION REFERENCE

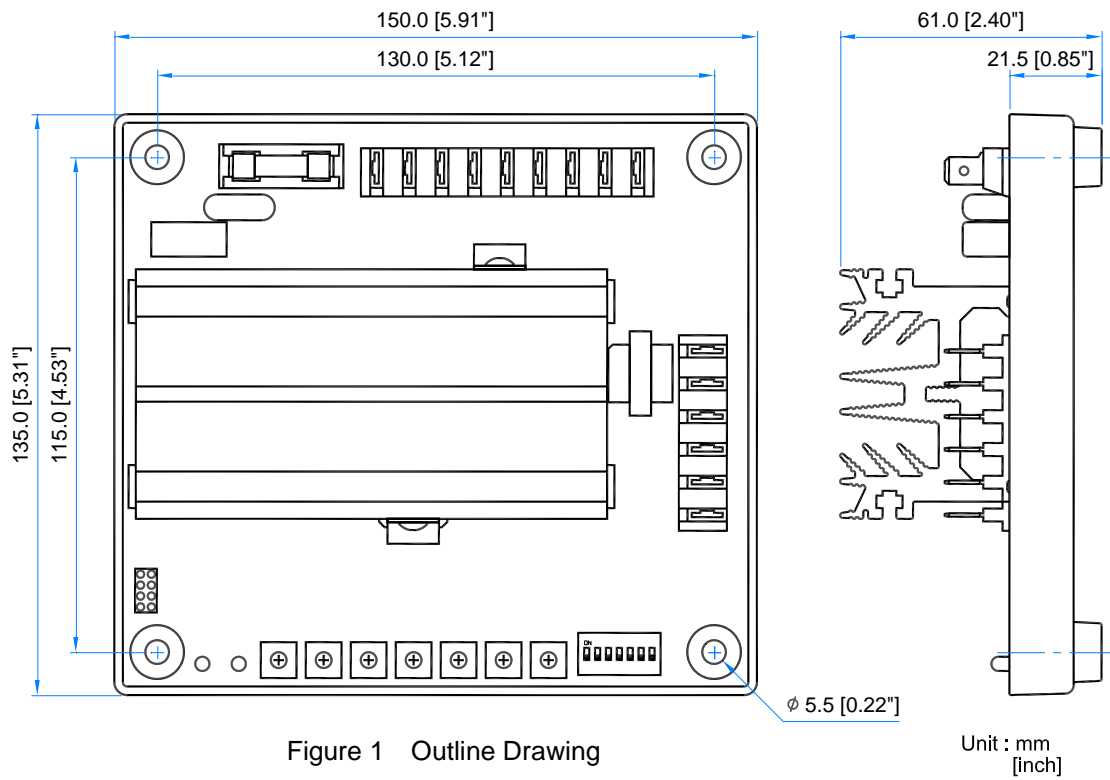

SECTION 3 : DIP SWITCH PROGRAMMING & VR ADJUSTMENTS

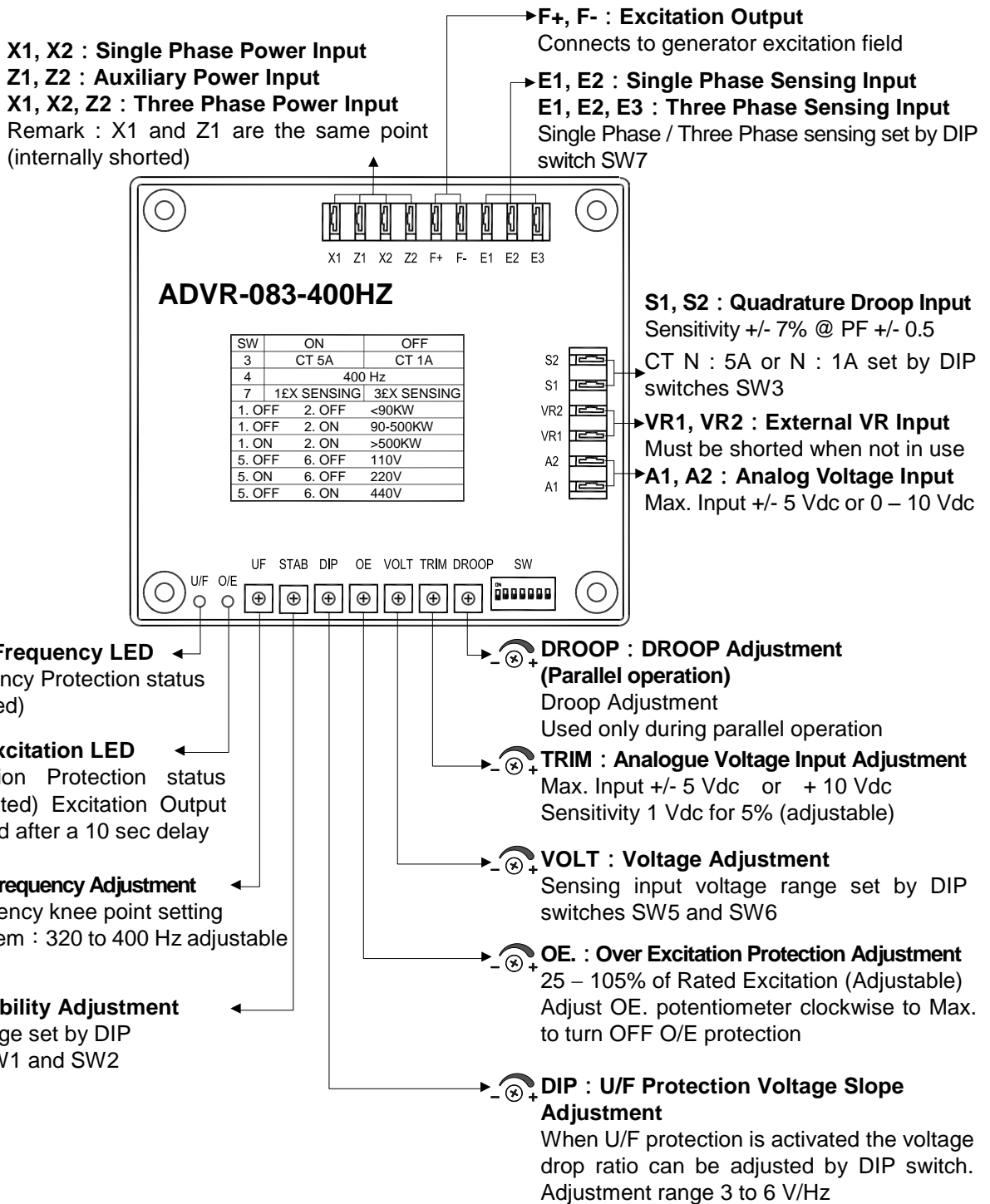

SECTION 4 : WIRING CONNECTIONS

Dotted lines represent a three-phase input. Do not connect if installed in single-phase system

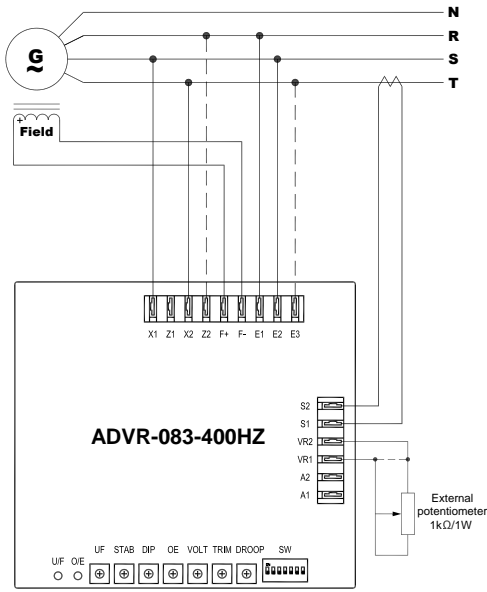

Figure 3 Self-Excited (SHUNT) 110/220 Vac Single phase / Three phase

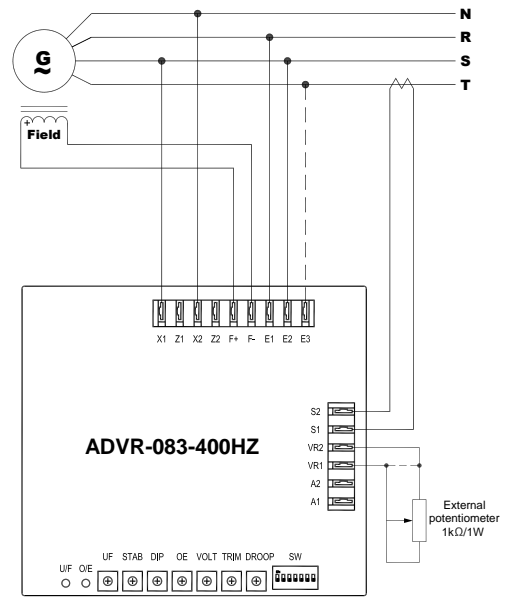

Figure 4 Self-Excited (SHUNT) 380/440 Vac Single phase / Three phase

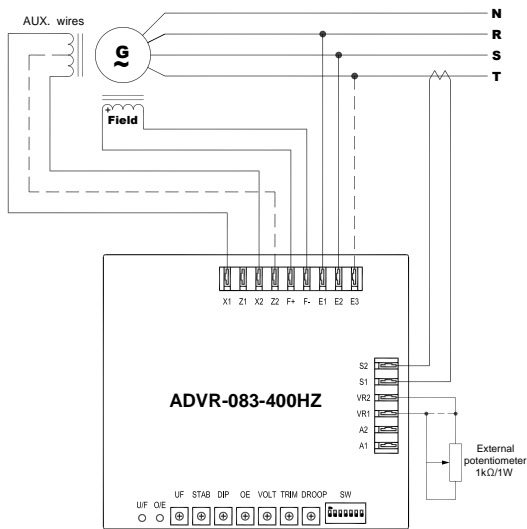

Figure 5 Auxiliary Winding 110/220/440 Vac Single phase / Three phase

ATTENTION

1. Before using a Megger or a Withstand Voltage Tester remove the wires connecting to the AVR to prevent high voltage damage to the regulator.
2. Improper setting of under-frequency protection could cause the output voltage of the unit to drop or become unstable under with changes in load. Avoid making any changes to the U/F setting unless necessary.
3. Turn off O/E in AVR when paralleling.

※ Use only the replacement fuses specified in this user manual.

※ Appearance and specifications of products are subject to change for improvement without prior notice.