

CH4612 & CH4624

Automatic Battery Charger user manual



GENERAL INFORMATION

A visual inspection of this product for damage during shipping is recommended before installation. Please contact your local supplier with any questions.

SECTION 1: IMPORTANT SAFETY INSTRUCTIONS

This manual contains important safety and operating instructions for battery charger Models CH4612 and CH4624. Read the manual carefully and follow the instructions before using your charger.

DANGER

High Voltage may result in a risk of fire, electric shock, injury or death.

WARNING

Batteries may generate explosive gases during normal operation and charging. Never smoke, light a flame, or generate any sparks near the battery.

- 1.1 This is not a power supply. Use only as a battery charger.
- 1.2 Built-in AC power fuses protected input. No external fuses are needed. Do not attempt to replace internal fuse, if it burns out.
- 1.3 Do not expose the battery charger to rain, snow or wet environments.
- 1.4 Do not disassemble the charger. Return to supplier when service and repair is needed.
- 1.5 Be very careful not to drop any metal tool on to the battery or charger. It may spark or short-circuit the battery or other electrical part, which in turn may cause an explosion.
- 1.6 To reduce the risk of damage to the electric plug and cord, pull using the plug rather than the cord when disconnecting the charger.
- 1.7 If battery acid or chemicals contact skin or clothing, wash immediately with soap and water.
- 1.8 If battery acid or chemicals comes into contact with your eye, immediately begin washing your eye with cold water before taking any other action and continue for at least 10 minutes. Get immediate medical attention.

SECTION 2: SPECIFICATIONS

Power Input

Voltage 100 – 277 Vac

Frequency 47 – 63 Hz

DC Output

CH4612 Voltage 13.6 Vdc / Current 5A Max.

CH4624 Voltage 27.2 Vdc / Current 3A Max.

DC Voltage Regulation

Less than +/- 1%

Charge Mode

Float

Efficiency

greater than 80% @ Full load

Low Battery Voltage Alarm Output Capacity

Solid State 0.5A @ 40 Vdc

Suitable Battery Type

Gel, Lead Acid & AGM

Protection

Constant output voltage, limited charge current

Reverse polarity & short circuit protections.

Environment

Operation Temperature -20 to +60 °C

Storage Temperature -30 to +80 °C

Relative Humidity Max. 90%

Vibration 5.0Gs @ 60 Hz

Mounting Type

Panel or DIN Rail Mount

Dimensions

175.0 (L) x 115.0 (W) x 60.0 (H) mm

7" (L) x 4.5" (W) x 2.4" (H)

Weight

0.52 Kg (1.15 Lbs) +/- 2%

UL Listed

File No. E471849

SECTION 3 : INSTALLATION AND OPERATION

CAUTION

Before beginning installation of this charger:

- Disconnect electrical power to the charger
- Read and follow all installation instructions
- Make sure charger cannot operate during installation
- Crimp and properly secure terminal lugs on to power wires to avoid shorts.

- 3.1 Check that the correct model charger is selected for your battery.
- 3.2 Verify your line voltage is correct.
- 3.3 Connect line voltage to the charger, then the "power indicator" should light up and the display show the output voltage and current.
- 3.4 Disconnect AC power before connecting the charger to the battery.
- 3.5 Turn AC power ON. The unit will automatically charge the battery with an adjusted current related to battery condition and cyclically show charging voltage and current on screen.
- 3.6 The charger is automatic and can always stay connected even during engine cranking and running.
- 3.7 For the model CH4612 to work the minimum battery voltage must be higher than 6 Vdc or the charger will automatically shut-down and all the indicators on the panel will turn off. (For model CH4624, the minimum battery voltage is 12 Vdc).
- 3.8 Voltage sensing circuit automatically stops charging when the battery is fully charged.
- 3.9 Input and output connection cable size $\geq 1.25\text{mm}^2$ (AWG 16).

SECTION 4: LOW DC VOLTAGE ALARM

For CH4612 when battery volt less than 10 Vdc

For CH4624 when battery volt less than 20 Vdc

"Low DC indicator alarm output." uses a solid state relay 0.5A connected to battery negative

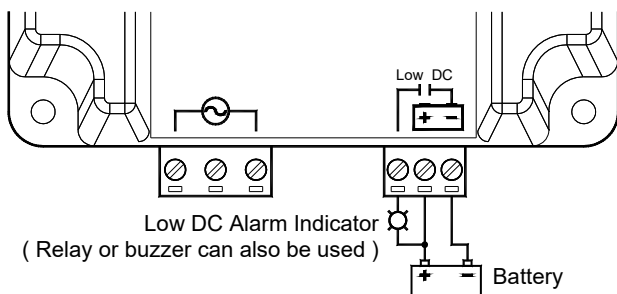

SECTION 5: DISPLAY & ALARM INDICATORS

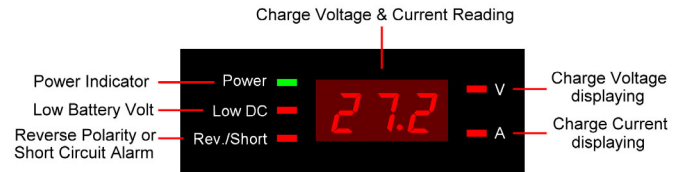

SECTION 6: OUTLINE / SIZE

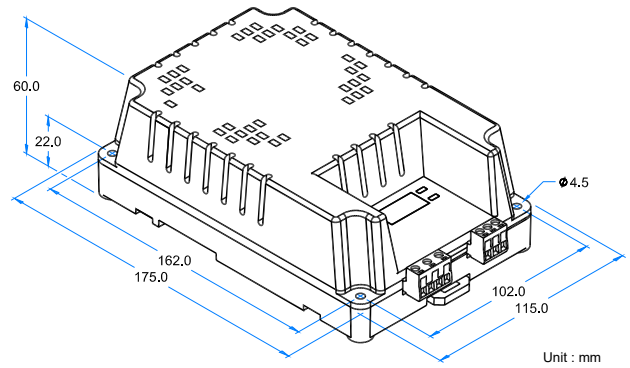

SECTION 7: DIN-RAIL ASSEMBLY INSTRUCTIONS

7.1 Charger Installation

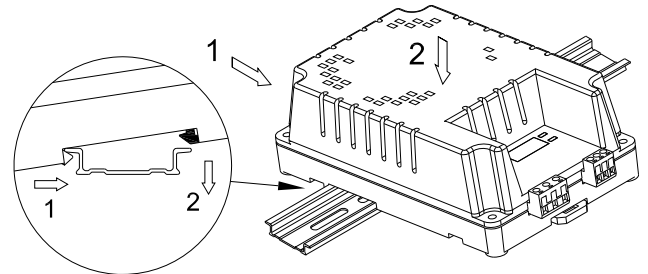

7.2 Dismount Charger

