

# GCU-100

## Automatic Genset Control and Protection Module

### Features

- Micro-processor auto control & protection
- Three sets of high illuminating LED display suitable for indoor and outdoor use
- Full function modularized design for easy installation
- All functions setting can be done directly on GCU-100 no need for PC connection \*
- All settings are recorded into the internal (EEPROM) and protected from erasure even without battery
- Optional USB / RS485 / Ethernet remote communication functions
- Free APP for monitor and operate your ATS & genset directly from your smart phone
- Easy to understand graphical warning signals
- Din rail terminal for easy installation
- IP65 waterproof front panel



\* User can program, change and cancel protection and warning settings according to the requirement.

### Protection & Alarm Status Indicators

- Engine Start Failure
- High Engine Temperature
- Engine Over & Under Speed
- Generator Over Load
- Charge Motor Failure
- Scheduled Maintenance Warning
- Emergency Stop Activated
- Low Engine Oil Pressure
- Low Fuel Level
- Abnormal AC Volt
- Abnormal DC Volt
- Free Programmable warning

### Panel Display

- Fixed or Circulating Full Phase Voltage, Current and Frequency
- Engine Operation Hours
- DC Voltage (Battery)
- Delay Countdown Display

### Specifications

<b>Power Input</b>	Voltage 9 to 35 Vdc (12V / 24V)	<b>CT Secondary Ratio</b>	5A
<b>Sensing Input</b>	Voltage 15 to 510 Vac	<b>Environment</b>	Operating Temperature -20 to +60 °C
	Frequency 50 / 60 Hz		Relative Humidity Max. 90%
<b>Power Dissipation</b>	Max. 5 watts	<b>Max. Vibration</b>	5 to 25 Hz
<b>MPU Signal Input</b>	Voltage +/-2 to +/-70 Vac		+/-1.6 mm
	Frequency Min. 100 Hz Max. 10 kHz		25 to 100 Hz
<b>CT Specification</b>	Burden Above 2.5 VA		a=4g

### Mechanical Specifications

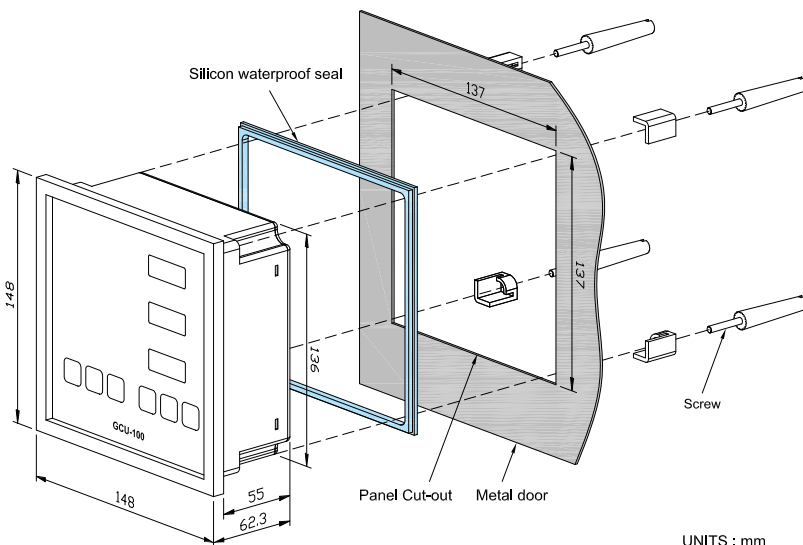

### Physical Specifications

<b>Panel Cut-Out</b>	137.0 x 137.0 +/-0.5 mm
<b>Dimension</b>	147.8 (L) x 147.8 (W) x 62.3 (H) mm
<b>Weight</b>	604 g +/-2%



**KUTAI ELECTRONICS INDUSTRY CO., LTD.**

TEL : +886-7-8121771 FAX : +886-7-8121775 Website : [www.kutai.com.tw](http://www.kutai.com.tw)  
Headquarters : No.3, Lane 201, Chien Fu St., Chyan Jenn Dist., Kaohsiung 80664, TAIWAN

**ISO 9001**  
**ETC**