

HTS2S080C1

HTS2S080C2

HTS Residential Automatic Transfer Switch (ATS)

2P 80Amp 110Vac & 220Vac applicable for On-Load Transfer

Features

- Capable of on-load transfer under rated voltage and current.
- Dual-power OFF position provides arc extinction time for enhanced safety.
- All-In-One Design – Integrated switch and microcomputer controller.
- Auto / Manu Selector – Equipped with an AUTO/MANU mode selector; the handle can be operated in MANU mode.
- Built-in Four High-Breaking Capacity Fuses
- Mechanical Lugs – Eliminates the need for crimp terminals.
- Switch Position Indicator Window – Provides clear visualization of conduction status.
- Transfer Failure Indicative LED.
- 2-second confirmation delay on power loss and restoration – Eliminate unnecessary switching by the ATS.
- Durable Switching Mechanism – Operation life exceeding 6,000 cycles
- Compliant with IEC 60947-6-1 international standard and AC-33A*1 utilization category.
- Flame retardance rating UL94-V0.
- The height of the HTS transfer switch is same as BH-type MCCB.



Patented: U.S. Pat. No. Pending
 TAIWAN Pat. No. Pending
 CHINA Pat. No. ZL 2025 2 0003676.X

- Suitable for automatic power transfer in residential buildings, telecom base stations or small-scale renewable energy systems.
- Optional RS-80 Engine Remote Start Module – Provides remote dry contact for engine start/stop and electrical signal output for Utility/Generator power connected to load.

Specifications

Operating Voltage (Ue)	110V : 90 Vac to 125 Vac	Static Power Consumption	Less than 0.3W
	220V : 180 Vac to 250 Vac		Changeover Delay Time
Rated Current (Ie)	80 Amp	Load Category	AC-33A *1
Operating Frequency	45 to 65 Hz	Equipment Classification	Class PC *2

*1 AC-33A : Electric motor loads, or mixed loads including motors, resistive load and less than 30% incandescent lamps.

*2 PC class : Capable of making and withstanding short-time short-circuit current, but not expected to break short-circuit current.

Model Number	Description
HTS2S080C1	2P, 1 Phase 2 Wire, 110Vac
HTS2S080C2	2P, 1 Phase 2 Wire, 220Vac

Dimensions

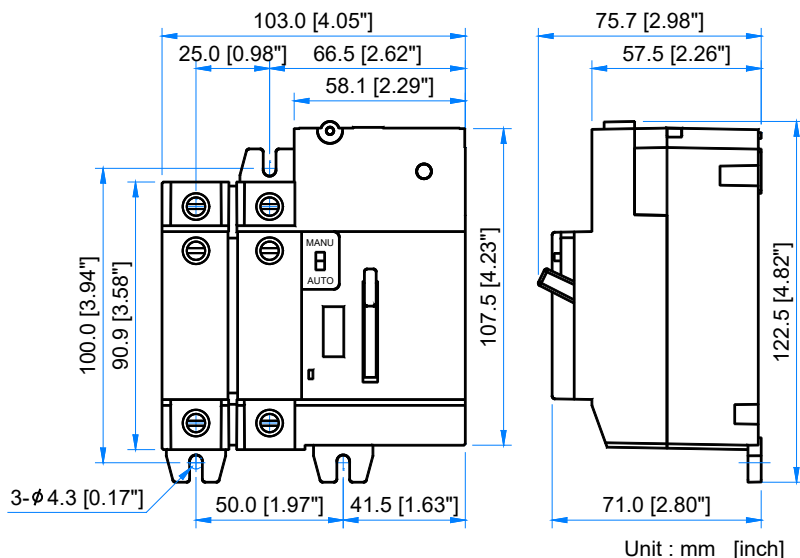

Environment

Operating Temperature	-20 to +50 °C
Storage Temperature	-30 to +80 °C
Relative Humidity	90% max.

Physical Specifications

Dimensions	122.5 (L) x 103.0 (W) x 75.7 (H) mm 4.82 (L) x 4.05 (W) x 2.98 (H) inch
Weight	736 g +/- 2% 1.62 lb +/- 2%

Accessories

M4L8 Bolt	3 pcs
Optional Accessories	
RS-80	HTS Engine Remote Start Module

Relative Product

HTS3S080C2	3P, 3 Phase 3 Wire, 220Vac
HTS1S080C2	3P, 1 Phase 3 Wire, 220Vac

