

PTS TYPE AUTOMATIC TRANSFER SWITCH (ATS)

Programmable Automatic Transfer Switch Operation Manual



Main Switch Rated Current 2P/3P/4P 400 Amp

Main Switch Rated Voltage 690 Vac

TAIWAN Pat. No. I881448

U.S. Patent Number : Pending

China Patents : Pending



KUTAI ELECTRONICS INDUSTRY CO., LTD.

TEL : +886-7-8121771

FAX : +886-7-8121775

Website : www.kutai.com.tw

Headquarters : No.3, Ln. 201, Qianfu St., Qianzhen Dist., Kaohsiung City 806037, Taiwan



TABLE OF CONTENTS

Section	Page
SECTION 1 : SAFETY PRECAUTIONS	
SECTION 2: PRODUCT OVERVIEW	
2.1 MODEL NO. DESCRIPTION	4
2.2 RATED CURRENT AND BREAKING CAPACITY (FOR CLASS CB ONLY)	4
2.3 ELECTRICAL SPECIFICATIONS	4
2.4 ASSEMBLY PRECAUTIONS	4
2.5 PRODUCT APPEARANCE (FRONT VIEW).....	5
2.6 PRODUCT APPEARANCE (REAR VIEW).....	5
2.7 MULTI-FUNCTION ROTARY KNOB	6
2.8 J1 TERMINAL DESCRIPTION.....	7
2.9 COLOR LCD DISPLAY	7
2.10 EVENT LOG SCREEN.....	7
2.11 LOCKOUT TAGOUT (LOTO).....	8
2.12 OUTLINE DIMENSIONS.....	8
SECTION 3: PARAMETER CONFIGURATION	
3.1 OPERATION PROCEDURE	9
3.2 PARAMETER TABLE	9
3.3 VOLTAGE CALIBRATION	10
3.4 REMOTE DIAGNOSTICS	11
SECTION 4: REMOTE MONITORING	
4.1 OVERVIEW OF REMOTE MONITORING FUNCTION	11
4.2 GLOSSARY.....	11
4.3 KTOOL APP HOME SCREEN	12
4.4 EVENT LOG SCREEN.....	12
4.5 CONNECTION BETWEEN CONTROL UNIT AND SERVER	13
4.5.1 WI-FI NETWORK CONNECTION SETUP	13
4.5.2 DYNAMIC IP NETWORK.....	13
4.5.3 MOBILE WI-FI ROUTER.....	14
4.5.4 WI-FI ANTENNA INSTALLATION	14
4.5.5 CONNECTION BETWEEN SMART MOBILE DEVICES AND THIS DEVICE	14
4.6 KTOOL® APPLICATION.....	14
4.6.1 KTOOL® APPLICATION DOWNLOAD	14
4.6.2 MEMBER ACCOUNT APPLICATION.....	15
4.6.2.1 REGISTER AN ACCOUNT VIA WEB BROWSER.....	15
4.6.3 CONTROL UNIT BINDING	15

4.6.4	EDIT OPERATOR AND VIEWER.....	15
4.6.5	UNBINDING	16
4.6.6	CONNECT TO THE CONTROL UNIT	16
4.7	REMOTE PARAMETER SETTING.....	16
4.8	ABOUT THIS DEVICE	16
4.9	SOFTWARE UPDATE	17
4.10	REMOTE MONITORING SERVICE FEE	17
4.11	PAYMENT METHODS.....	17
4.11.1	PAYMENT ON KUTAI WEBSITE.....	17

SECTION 5: OPTIONAL ACCESSORIES

5	OPTIONAL ACCESSORIES	17
---	----------------------------	----

SECTION 1 : SAFETY PRECAUTIONS

⚠ WARNING : The automatic transfer switch must be installed, wired and configured by qualified technical personnel. Improper installation, wiring, or parameter configuration may cause personal injury or equipment damage.

NOTICE : The content highlighted in blue in this manual describes advanced functions that are less commonly used. If these functions are not currently in use, you may temporarily skip this content and refer back to it when needed.

SECTION 2: PRODUCT OVERVIEW

2.1 Model No. description

Product	Types of AC Distribution System	Safety Certification	Rated Current	IEC Category	Applicable Voltages (Vac)	Enclosure
PTS	3	S	400	B	2	C
1	3P (1P3W)	U UL Certified	250 250A	B Class CB *1	1 100 / 110 / 120	Blank No enclosure
2	2P (1P2W)	S Standard (No UL)	300 300A	C Class PC *2	2 200 / 220 / 240	C With indoor enclosure
3	3P (3P3W)		350 350A		3 380 / 415	E With outdoor enclosure
4	4P (3P4W)		400 400A		4 440 / 460 / 480	

*1 Class CB : Provides over current protection. The main contacts are capable of making and breaking short circuit currents.
 *2 Class PC : Capable of making and withstanding short-time short-circuit current, but not expected to break short-circuit current.

⚠ CAUTION : Using a product model with a voltage range incompatible with the actual site voltage may result in improper operation of the transfer switch or potential damage to connected equipment.

2.2 Rated current and breaking capacity (For Class CB Only)

MCCB Rated Operating Current & AC Rated Breaking Capacity						
No. of Poles	Rated Insulation Voltage Ui (V)	Rated Current Ie (A) Ambient Temperature 40°C	AC Rated Breaking Capacity IEC 60947-2 Icu / Ics (KA)			
			220V / 240V	380V / 415V	440V	550V
2P / 3P / 4P	690	400	50 / 25	30 / 15	25 / 13	20 / 10

● Class PC : Short-Time Withstand Current (Icw) 10KA / 25ms.

2.3 Electrical Specifications

Item	Specification
Operating Voltage (Ue)	Refer to PTS Model Desc.
Rated Current (Ie)	400 Amp
Rated Frequency	45 to 65 Hz
Load Category	AC-33A*3
TDEN Time Delay Emergency to Normal	0 to 999 seconds
TDNE Time Delay Normal to Emergency	0 to 250 seconds
TDES Time Delay Engine Start	0 to 15 seconds
TDEC Time Delay Engine Cool-down	0 to 250 seconds
TDOF Time Delay in OFF position	0 to 99 seconds

Item	Specification
Protection Fuse Spec.	1A @ 500 Vac
Static Power Consumption	Below 0.3W
Remote Start Signal Output	7A @ 30 Vdc Max.
Utility Power to Load Signal Output	3A @ 250 Vac Max.
Generator Power to Load Signal Output	3A @ 250 Vac Max.
User Configurable Output	7 A @ 250 Vac Max.
Operating Temperature	-20 to +50 °C
Storage Temperature	-30 to +80 °C
Relative Humidity	90% max.

*3 AC-33A : Electric motor loads, or mixed loads including motors, resistive load and less than 30% incandescent lamps.

2.4 Assembly Precautions

1. During assembly and wiring, power cables must not obstruct the proper operation of the actuator mechanism.
2. For a three-phase system, the wiring phase sequence of both Utility Power and Generator Power must match the indicated markings.
3. PTS should be installed inside an insect-proof electrical enclosure, and should not be installed in environments subject to strong vibrations, excessive humidity, heavy dust or corrosive gases.

- All ATS wiring cables should be routed away from the top of the enclosure to prevent water ingress along the cables, which may cause equipment short-circuiting.
- The ATS enclosure shall be equipped with a lock to prevent unauthorized personnel from operating it or causing hazards due to accidental contact.

2.5 Product Appearance (Front View)

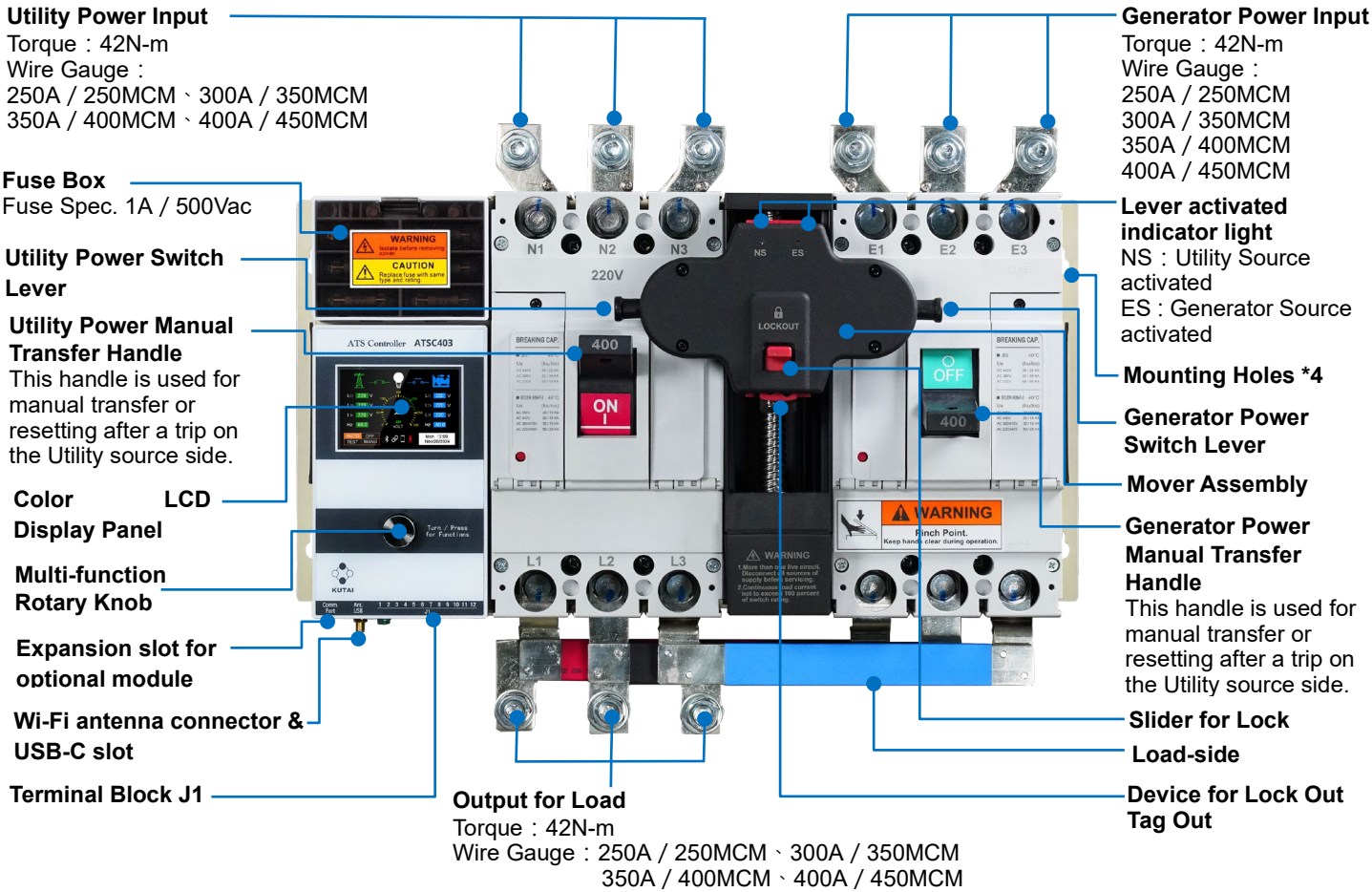

- * 1 : Manual reset is only applicable to Class CB type.
- * 2 : When switching manually, first set the controller to OFF mode, and avoid both switches being in the ON position.

CAUTION Improper wire gauge or tightening torque may lead to safety hazards. Insufficient torque can cause poor contact and overheating, resulting in equipment failure or fire.

2.6 Product Appearance (Rear View)

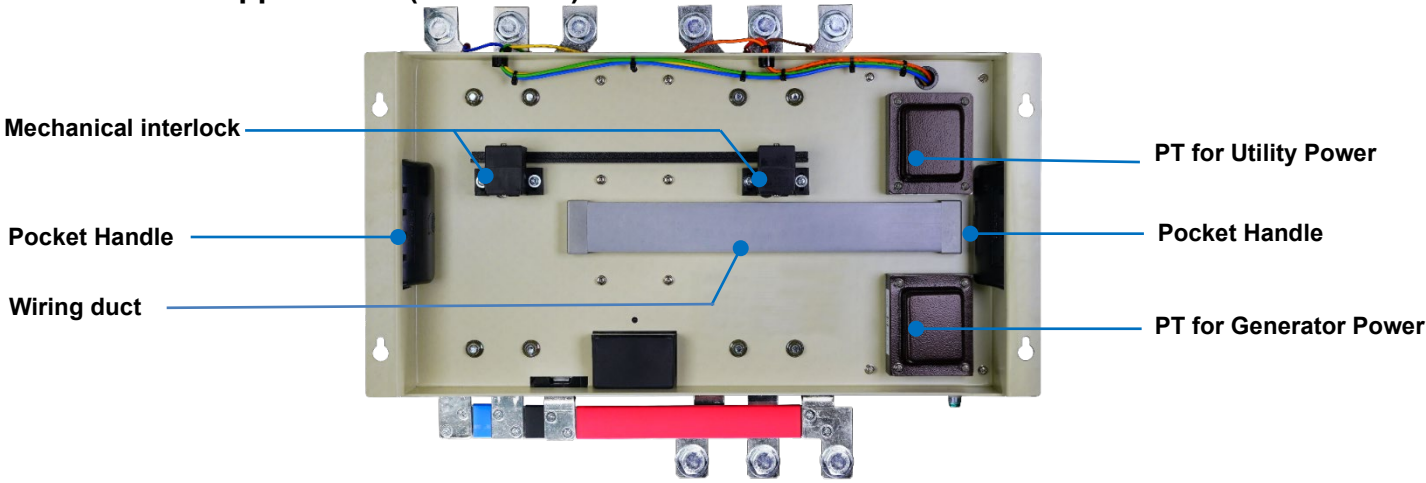

2.7 Multi-Function Rotary Knob

Operation Instructions : Use the Multi-function Rotary Knob to scroll through menu options. Pressing the knob confirms the current selection or enters the selected submenu.

Pressing the multi-function rotary knob to enter the main function menu. The menu options are described as follows:

- **AUTO Mode** : Continuously monitors the status of both the Utility and Generator power sources and automatically executes generator start/stop and source transfer based on internal system settings.
- **OFF Mode** : 1) Stops all ATS controller functions.
2) Remote start signal output open circuit
3) Cease any active fault alarms (visual and audio).
- **TEST Mode** : Test Mode: Used to simulate a power outage of the Utility Power. In this mode, the engine should start, and depending on the setting of Item 27, perform a generator test with or without load.
- **Electrical Manual** : In this mode, the user may manually execute the following operations.
 - ✧ **Engine Start (Shutdown)**
 - ✧ **Utility Power ON (OFF)**
 - ✧ **Generator Power ON (OFF)**
- **Event Log** : Displays a list of historical events to assist in fault diagnosis and analysis.
- **Lockout** : When executing lockout, the load will be automatically disconnected and the generator set will be shut down. The user must press the Slider for lock and apply a padlock to prevent unintended power connection, which may result in electric shock or equipment damage. For details, *refer to 2.11*.
- **Other Functions** : Includes the following configurable items
 - ✧ **System Configuration** : Must be accessed in OFF mode. Otherwise, parameters can only be browsed, not modified. *Refer to 3.1*.
 - ✧ **Bluetooth Connection Enable(Disable)** : Enables or disables the built-in Bluetooth connection. *Refer to 4.5*
 - ✧ **Wi-Fi Connection Enable(Disable)** : Enables or disables the built-in Wi-Fi connection. *Refer to 4.5*
 - ✧ **Remote Control Enable(Disable)** : When enabled, the *Operator* can remotely control the ATS and modify system parameters. When disabled, only monitoring is allowed.
 - ✧ **Firmware Update** : If the screen displays a firmware update prompt , this option can be used to update the firmware in OFF mode.
 - ✧ **Manual Lubrication (Anti-Rust Mode)**: During execution, the drive mechanism assembly moves up and down twice without changing the switch position.
 - ✧ **Unbind Device** : Remove all existing accounts from the binding relationship with this device, preventing any further remote operation or monitoring. *Refer to 4.6.5*
 - ✧ **Remote Diagnostics** : The control unit executes Utility Power and Generator Power transfer operations and displays codes for settings, sensor status, and input voltage conditions, enabling manufacturer technicians to analyze the causes of unexpected events. **Do not execute this function unless necessary.** *Refer to 3.4*
- **About** : The content includes the control unit product serial number, firmware version, SSID of the currently connected Wi-Fi, MAC address and IP address.

NOTICE : When a conflict occurs between local and remote operation commands, the device will execute the latest command.

2.8 J1 Terminal Description

Terminal	Function Description	Terminal Location Reference
J1-1 & J1-2	Remote start signal dry contact output	
J1-3 & J1-4	Generator power source ON auxiliary dry contact	
J1-5 & J1-6	Utility power source ON auxiliary dry contact	
J1-7 & J1-8	User Configurable output dry contact. *Refer to Configuration Item 38	
J1-9	DC Power B+ Input 9 to 36Vdc	
J1-10	DC Power B- Input 9 to 36Vdc	
J1-11 & J1-12	User-configurable input terminal must be a dry contact signal *Refer to Parameter Table Item 37	

2.9 Color LCD Display

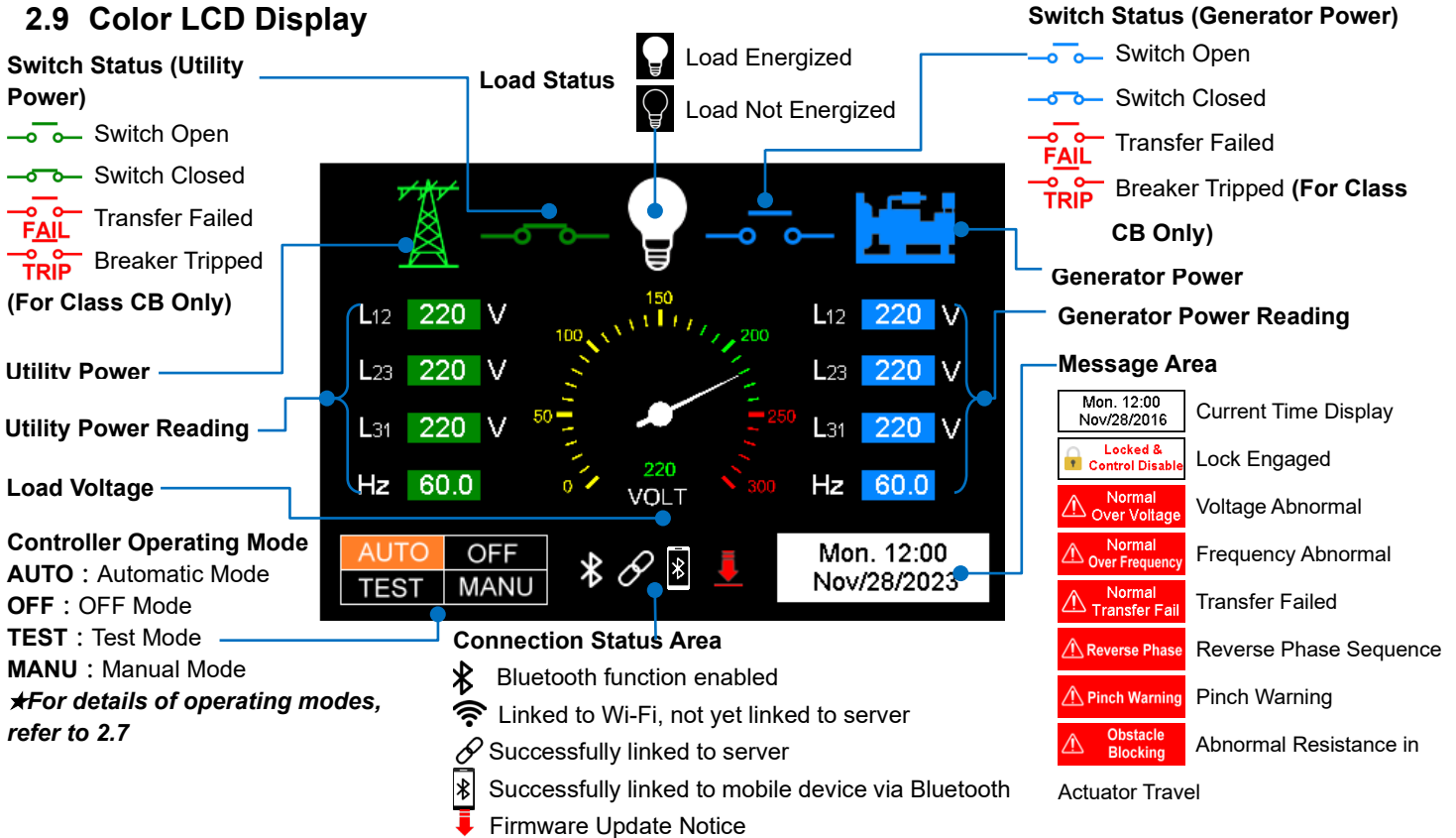

2.10 Event Log Screen

The PTS control unit provides access to the latest 250 event logs, including information such as transfer operations, mode changes, overload trips, transfer failures, and power quality anomalies, along with timestamps. This facilitates fault tracing and root cause analysis.

Function Menu ▶ Event Logs ▶ Event Log Screen

Event LOGs	
001. Set to OFF Mode (Remote)	15:11 Nov/28/2023
002. Utility Over Voltage	15:09 Nov/28/2023
003. Set to AUTO Mode (Local)	12:00 Nov/29/2023
004. Generator Over Voltage	23:21 Nov/28/2023
005. Transferring from Utility to Generator	12:00 Nov/28/2023
006. Utility Over Frequency	22:00 Otc/21/2023
EXIT	

Event Logs :

1. Rotate the Multi-function Rotary Knob to scroll through event log pages.
2. When *Exit* is pressed or no operation is performed for 30 seconds, the system will automatically return to the main screen.

2.11 Lockout Tagout (LOTO)

Lockout Tagout is a mandatory locking device. During its operation, both switches are locked in the OFF position by the lever, all controller operations and functions are disabled, and the remote start contact remains open. Follow the steps below to perform lockout:

Function Menu ▶ Execute Lockout ▶ Confirm ▶ Follow the steps below to complete

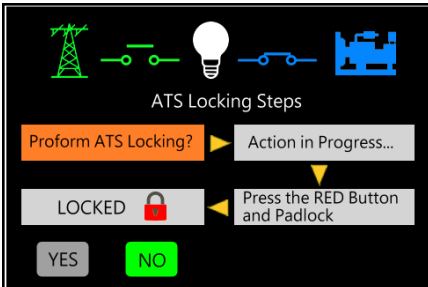

Step 1: Select the **Yes** button at the bottom of the screen and press the Multi-function Rotary Knob to confirm.

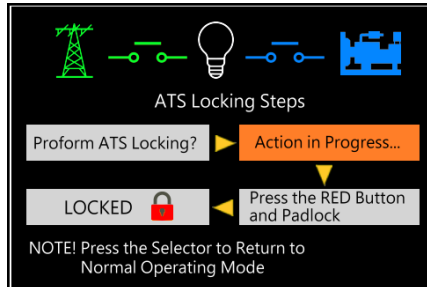

Step 2: The internal mechanical mechanism switches both sides to the OFF position and opens the remote start contact.

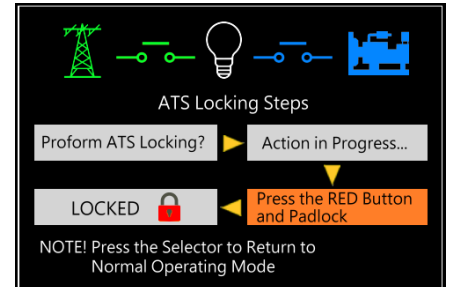

Step 3: At this point, the user should press down the lockout slider and apply the padlock.

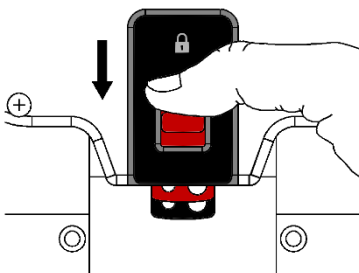

Step 4: Press down the lockout slider.

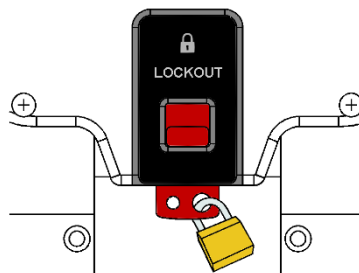

Step 5: Apply the padlock.

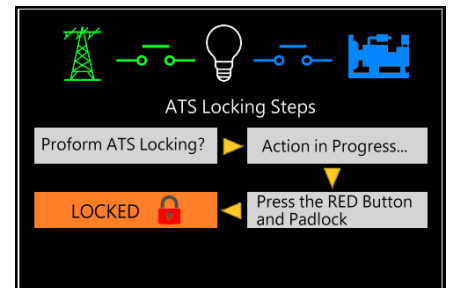

Step 6: Lockout Tagout is now complete.

CAUTION : Operators must follow the Lockout Tagout (LOTO) procedure to apply the padlock and warning tag, preventing accidental energization that could result in electric shock or equipment damage. During the lockout period, all ATS operations and transfer functions are forcibly disabled.

CAUTION : This LOTO function can only be executed when at least one side of the AC power supply is normal.

2.12 Outline Dimensions

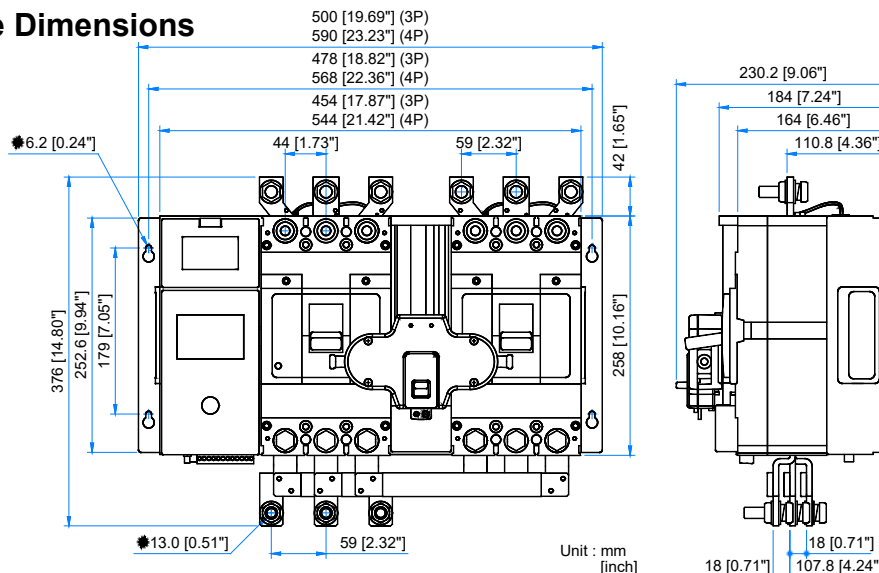

SECTION 3: PARAMETER CONFIGURATION

3.1 Operation Procedure

Rotate the Multi-function Rotary Knob to **OFF Mode** ▶ *Function Menu* ▶ *Other Functions* ▶ *System Parameter Configuration* ▶ Select Item and *Confirm* ▶ Adjust to the desired content and *Confirm* ▶ Repeat the above steps until all items are configured ▶ *Exit*

3.2 Parameter Table

LINE	DESCRIPTION	VALUE	FACTORY SETTING
01	Language / Idioma / 語言 / 言語	English / Español / 繁體中文 / 日本語	English
02	Phase	3P3W (3P) / 1P2W (Single Phase) / 1P3W	3P3W
03	Nominal Voltage	100/110/120/200/220/240/380/415/440/460/480	220
04	TDEN (Time Delay Emergency to Normal)	00 – 999 sec.	10 sec
05	TDNE (Time Delay Normal to Emergency)	00 – 250 sec.	10 sec
06	TDES (Time Delay Engine Start)	00 – 15 sec.	5 sec
07	TDEC (Time Delay Engine Cool-down)	00 – 250 sec.	30 sec
08	TDOF *1	00 – 99 sec.	5 sec
09	Utility Power Overvoltage Setting	105 - 115%	110%
10	Utility Power Undervoltage Setting	85 - 95%	90%
11	Utility Power Voltage Abnormal Delay Time	00 – 99 sec. (00 means voltage protection is disabled)	1 sec
12	Utility Power Overfrequency Setting	51 – 75 Hz	65 Hz
13	Utility Power Underfrequency Setting	40 – 59 Hz	55 Hz
14	Utility Power Frequency Abnormal Delay Time	00 – 99 sec. (00 means frequency protection is disabled)	1 sec
15	Generator Power Overvoltage Setting	105 - 115%	110%
16	Generator Power Undervoltage Setting	85 - 95%	90%
17	Generator Power Voltage Abnormal Delay Time	00 – 99 sec. (00 means voltage protection is disabled)	1 sec
18	Generator Power Overfrequency Setting	51 – 75 Hz	65 Hz
19	Generator Power Underfrequency Setting	40 – 59 Hz	55 Hz
20	Generator Power Frequency Abnormal Delay Time	00 – 99 sec. (0 means frequency protection is disabled)	1 sec
21	Set Current Year	2024 - 2099	current
22	Set Current Month	01 – 12	current
23	Set Current Date	01 – 31	current
24	Set Current Day of the Week	Monday to Sunday	current
25	Set Current Hour	00 – 23	current
26	Set Current Minute	00 – 59	current
27	Test Mode with load or without load	With Load or Without Load	With Load
28	Phase Sequence Verification	Enabled or Disabled	Enabled
29	Screen brightness	1 – 10	8
30	Voltage Calibration	Enter AC Voltage Calibration	

*1 **TDOF**: The delay time during the transfer process in which both user-specified switches remain in the OFF position.

LINE	DESCRIPTION	VALUE	FACTORY SETTING
31	Restore to Default Settings?	Yes or No	No
32	Specify the day of the week for automatic test execution.	Monday to Sunday	Saturday
33	Specify Auto Test Execution Time	00 – 23 (24-hour format)	12
34	Specify Auto Test Interval	1 - 4 Weeks	1 Weeks
35	Specify Auto Test Duration	00 – 99 Mins. (00 = Auto Test Disabled)	00 Mins.
36	Auto test with load or without load?	With Load or Without Load	With Load
37	User Configurable Input Function (Activated when contact is closed)	Fire Alarm Signal / Generator Load Test / Generator Without Load Test	Fire Alarm Signal
38	User Configurable Output Function (Select one of five options only)	1. Transfer Failure Alarm / 2. Pre-transfer notification signal output / 3. Pre-test alert function / 4. Generator Power Transfer Auxiliary Contact / 5. Non-AUTO Mode Indicator	2. Pre-transfer notification signal output
39	Pre-notification Time for Transfer / Auto Test	00 – 99 sec.	10 sec
40	KCU-05/07 Module Address	00 – 99 (00 : Disables KCU-05/07 Module)	00
41	KCU-05 Baud Rate	2400/4800/9600/14400/19200/38400/57600/115200	38400
42	KCU-05 Parity Bit	00=N81 01=N82 02=E81 03=O81	N81
43	Delete event logs?	Yes or No	No
44	Automatic oil lubrication and anti-rust interval days (executed at 00:00).	0 – 30 Day/Time (0: Function Disabled)	7 Day
45	Auto Mode Pause Schedule (Start Time – Day of the Week) ★ Options (45–48) will appear only when DC power input is connected.	No Schedule / Monday / Tuesday / Wednesday / Thursday / Friday / Saturday / Sunday / Daily	No Schedule
46	Pause Period in Auto Mode, Start Time – Hour	00 – 23	20
47	Pause Period in Auto Mode, End Time –Day of the Week	Monday / Tuesday / Wednesday / Thursday / Friday / Saturday / Sunday	Sunday
48	Pause Period in Auto Mode, End Time –Hour	00 – 23	08

*1 **Auto Mode Pause Schedule:** To eliminate unnecessary generator operation. During this period, the controller continues to monitor the power status, but all automatic control functions are suspended.

3.3 Voltage Calibration

The controller's RMS voltage readings for the three phases of both Utility and Generator Power sources have been precisely calibrated at the factory. Do not adjust unless necessary.

Turn the Multi-function Rotary Knob to OFF mode ► Main Menu ► *Other Functions* ► *System Parameter Setting* ► Item 30: *Voltage Calibration* ► AC Voltage Adjustment Screen ► Select the phase to adjust and Confirm ► Adjust to the correct voltage value and Confirm ► Repeat the above steps for all phases ► *Exit*

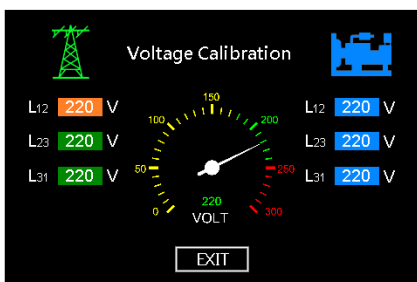

Phase Selection Screen for AC Voltage Calibration

Rotate the knob to switch the orange block between different phases, then press the knob to enter value calibration.

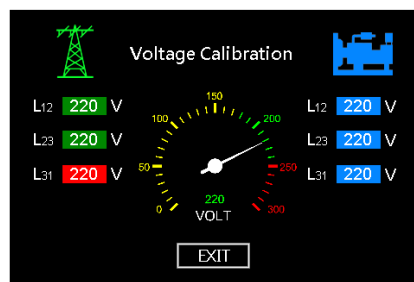

Voltage Reading Calibration Screen

When entering value calibration, the selected phase will turn red. Then rotating the knob allows the value to be changed.

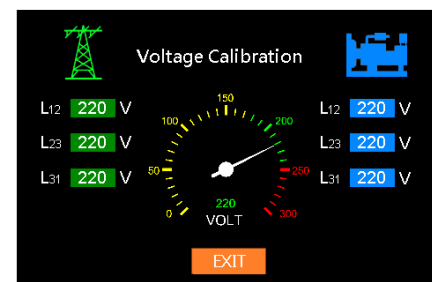

Exit Voltage Calibration

Press the knob to select *Exit*.

3.4 Remote Diagnostics

Once an unexpected event occurs, **Remote Diagnostics** may be accessed from the Main Function Menu. The system will perform a transfer operation between Utility Power and Generator Power (under certain conditions, the transfer may not occur). After the transfer operation is completed, the display will show information such as settings, sensor status, and input voltage conditions. Take a photo of this screen and provide it to the manufacturer's technical personnel for analysis of the unexpected event. Select **Exit** or wait 30 seconds for the screen will return to the main menu.

Operation Steps:

Rotate the knob to OFF Mode ► Main Function Menu ► **Other Functions** ► **Remote Diagnostics** ► **Confirm**

Notes:

During the Remote Diagnostics process, the control unit may execute a transfer operation between Utility Power and Generator Power. Ensure beforehand that such operation will not affect the field load. Do not execute this function unless necessary.

※ The following section provides operating instructions for the remote connection function. If you need to use this function, be sure to read this section carefully. ※

SECTION 4: REMOTE MONITORING

4.1 Overview of Remote Monitoring Function

Supports downloading the KTool® App on iOS and Android platforms, allowing users to remotely perform the following operations through the App:

- Monitor all real-time statuses, power readings, and fault conditions of the PTS.
- Receive push notifications for fault alarms, power quality abnormalities, and power transfer prompts.
- View event log contents to assist with remote fault diagnosis.

Three communication connection options are available:

Wi-Fi Network (see 4.5.1), Mobile Wi-Fi Hotspot (see 4.5.3), and Dynamic IP Network (see 4.5.2).

4.2 Glossary

Glossary	Description
<i>Owner</i>	Acquisition and modification of owner identity (see 4.6.3) with the following privileges: 1) Once the <i>Owner</i> is bound to the device, the account holds the roles of <i>Owner</i> , <i>Operator</i> , and <i>Viewer</i> . The <i>Owner</i> can edit <i>Operator</i> and <i>Viewer</i> roles as well as the device name. 2) During the period when <i>Operator</i> privilege was transferred to another user, the <i>Owner</i> will be unable to operate the device remotely. 3) Erase event logs.
<i>Operator</i>	Has the authority to remotely operate this device, modify system parameter settings, and monitor all device information. Only one account on this device can hold <i>Operator</i> privileges.
<i>Viewer</i>	<i>Viewer</i> accounts can only monitor all device information without any operation privileges. Up to 7 <i>Viewer</i> is allowed to log in simultaneously
<i>Binding</i>	To use the remote monitoring function, the device <i>Owner</i> must perform the binding process and authorize the <i>Operator</i> and <i>Viewer</i> roles. Any unauthorized connection will be rejected by the server host for remote access.
<i>Local Operation</i>	Refers to the user being able to operate directly on the device locally.
<i>Remote Operation</i>	Indicates that the <i>Operator</i> , having installed the KTool® App, can operate the device remotely.
※ In this manual, italicized text indicates terms with special definitions.	

4.3 KTOOL APP Home Screen

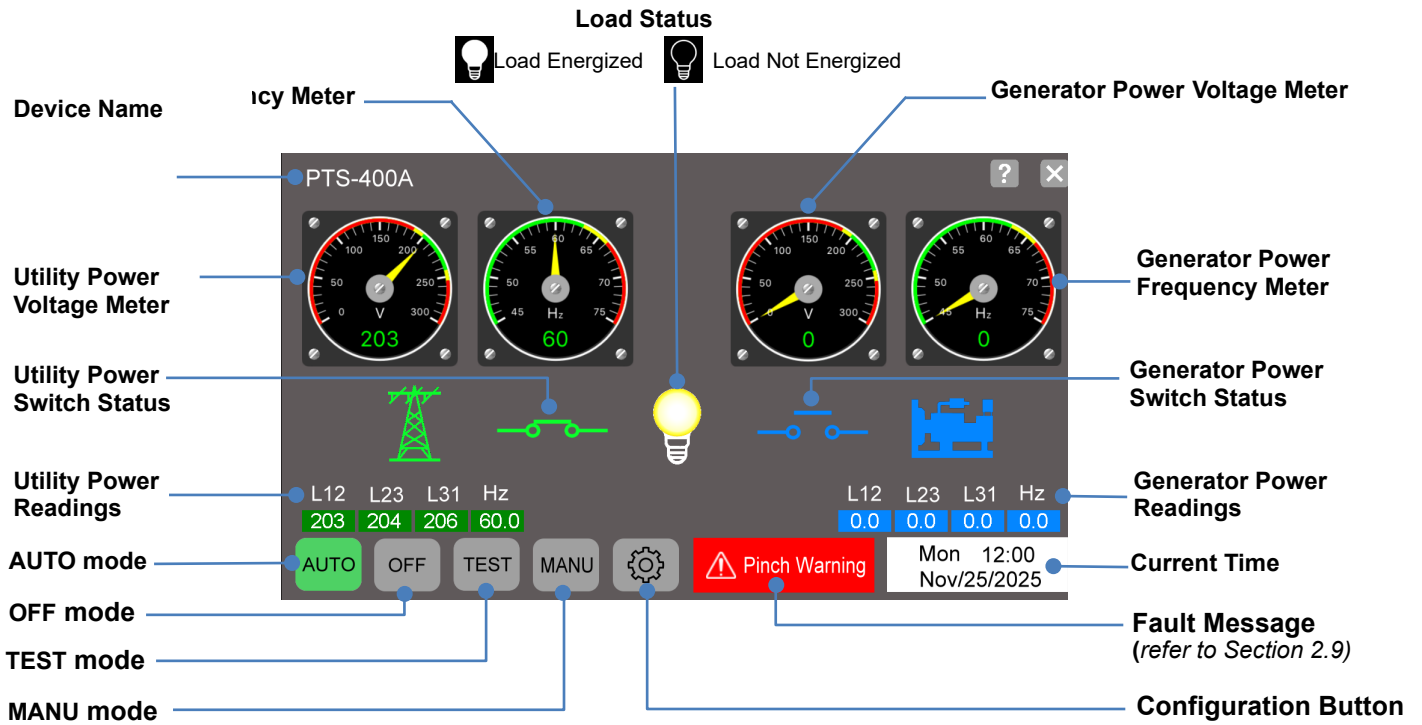

4.4 Event Log Screen

Up to the latest 250 event history records, including the occurrence time and event details.

Time Stamp **Event** : Includes records of operations, faults, alarms, and generator start/stop.

Details

Item	mm/dd/yy	Time	Event	Details	jerry ?
0001	09/23/25	13:58	MANU	Transferring from Generator to Utility	
0002	09/23/25	13:57	MANU	Transferring from Utility to Generator	
0003	09/23/25	13:47	MANU	Set to MANU Mode	
0004	09/23/25	13:46	AUTO	Transferring from Generator to Utility	
0005	09/23/25	13:45	AUTO	Set to AUTO Mode	
0006	09/23/25	13:45	MANU	Transferring from Utility to Generator	
0007	09/23/25	13:43	Warning	Utility Under Voltage	

4.5 Connection Between Control Unit and Server



4.5.1 Wi-Fi network Connection Setup

This device requires a smart mobile device with the KTool App installed to configure the Wi-Fi SSID and password via Bluetooth connection. Once the symbol  is displayed in the message area, it indicates that the device has established a connection with the server.

The setup procedure is as follows:

Controller side: *Menu* ► *Other Functions* ► *Enable Bluetooth* ► *Enable Wi-Fi* ► *Exit*

KTool App Operation on Mobile Device:

iOS Operation	Android Operation
<p>Step 1: Apple iOS mobile device connect to the Wi-Fi network intended for PTS-400 device.</p> <p>Step 2: Open the <i>KTool</i> App and tap Bluetooth devices.</p> <p>Step 3: Select the device to be configured according to its serial number. Tap  to rescan.</p> <p>Step 4: Tap Internet</p> <p>Step 5: Enter the Wi-Fi Password and tap Confirm.</p> <p>Step 6: Go back to Step 4 screen Wi-Fi SSID and password setup completed.</p>	<p>Step 1 : Open the <i>KTool</i> App and tap Bluetooth devices.</p> <p>Step 2: Select the device to be configured according to its serial number. Tap  to rescan.</p> <p>Step 3: Tap Internet</p> <p>Step 4: Select the desired Wi-Fi name,</p> <p>Step 5: Enter the Wi-Fi Password and tap Confirm.</p> <p>Step 6: Go back to Step 3 screen Wi-Fi SSID and password setup completed.</p>

Note: It may take few minutes for the PTS-400 to connect with the server after setup completed.

4.5.2 Dynamic IP Network

When using a dynamic IP network for connection, disable the firewall of the communication port to prevent blocking of data transmission. The controller will automatically obtain an IP address and connect to Kutai server.

If the network in use is configured with a static IP, direct connection will not be possible. In this case, an IP router that supports dynamic IP allocation must be installed to provide the DHCP (dynamic IP) network environment required for the controller connection.

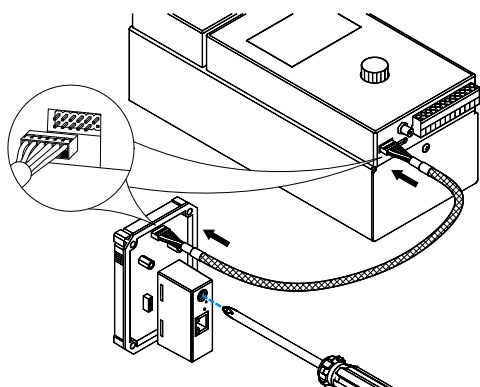

Using a dynamic IP network connection requires the following optional components (refer to Chapter 5 Optional Accessories):

1. KCU-31 (Ethernet Remote Communication Module for Dynamic IP)
2. KCU-IF or CTM-3K
3. KCU Communication Module Connection Cable (1 m)
4. Refer to the left diagram for installation method

CAUTION

Before performing installation, removal, or wiring of the KCU module, be sure to completely turn off all power sources to ensure safe operation.

4.5.3 Mobile Wi-Fi Router

When the PTS installation site cannot provide a Wi-Fi environment or Dynamic IP network connection, a mobile Wi-Fi hotspot with a 2.4G Wi-Fi band must be purchased from a local telecom operator to provide Wi-Fi access for the controller. For the setup procedure, refer to Section 4.5.1.

Precautions for Installing the Mobile Wi-Fi Router:

1. Do not install the mobile Wi-Fi Router inside the ATS electrical enclosure to avoid signal shielding by metal.
2. Ensure the installation distance allows the controller to remain within the Wi-Fi signal coverage range.
3. For outdoor installations, ensure proper waterproofing and vibration protection.

4.5.4 Wi-Fi Antenna Installation

When this device is installed inside a metal electrical enclosure and connected via Wi-Fi for monitoring, the external Wi-Fi signal may be shielded by the enclosure, causing intermittent disconnection between the controller and the server.

In this case, a Wi-Fi antenna should be optionally installed outside the electrical enclosure to provide a stable data transmission environment (see Chapter 5 Optional Accessories). The antenna installation method is shown in below figure.

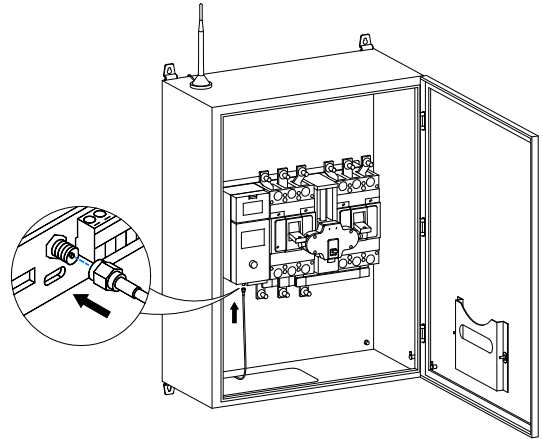

4.5.5 Connection Between Smart Mobile Devices and This Device

All *Owner*, *Operator*, or *Viewers* who use the remote monitoring function must apply for a personal member account. The steps are as follows:

1. Connection steps for *Owner*

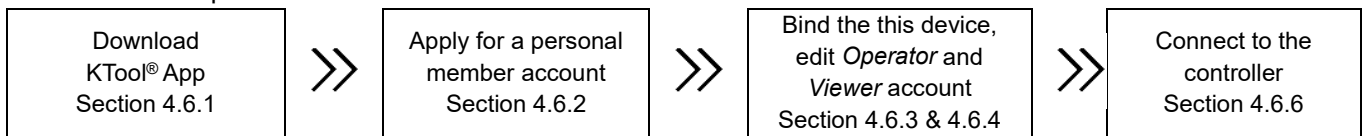

2. Connection steps for *Operator* and *Viewer*

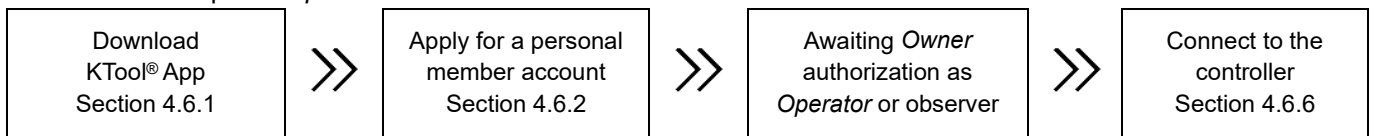

4.6 KTool® Application

4.6.1 KTool® Application Download

The KTool® APP is available in both iOS and Android versions. The user can download it from the locations below or by scanning the QR code.

1. App Store : download the KTool® APP
2. Google Play : download the KTool® APP

Apple iOS



Android



NOTICE : If Google Service is not available in a country, the KTool® APP will not support Android operating system services, such as in Mainland China, North Korea, and other regions.

4.6.2 Member Account Application

A personal member account can be registered through the following instruction.

4.6.2.1 Register an Account via Web Browser

Kutai official website www.kutai.com.tw ► **Member Center** ► **CREATE AN ACCOUNT** ► Carefully read the Terms of Service, enter the captcha code then click **I Agree** ► Sequentially fill in **User Name, Account (email), Password, and Confirm Password**, then enter the captcha code again, click **submit** ► Log in to the registered email, read the message sent by the membership system ► **Activation link** ► Complete member account registration.

NOTICE : After the membership account application has passed system review, the system will automatically send a verification email to the email address provided during registration. The email address must be valid and capable of receiving messages. Users must complete the account activation process within 30 minutes after the verification email is sent. If the activation is not completed within the time limit, the verification email will automatically expire, and a new account application will be required.

4.6.3 Control Unit Binding

All devices intended for remote monitoring must first complete the device binding procedure. The account used during binding will be set as the *Owner* of the device.

When binding the device, the control module must be connected with the server. If the device is not connected, or if the entered product serial number is incorrect, the system will display the message "Device Offline."

If the control module has already been bound to another account, it must first be unbound before it can be re-bound; otherwise, the system will display the prompt message "This device is already bound."

- **iOS and Android Operation** : KTool® APP ► Tap **Device Management** ► Enter your **Account / Password** ► Tap **Login** ► Click the "+" sign in the upper left corner ► Tap **New Devices** ► Enter **Device Serial Number** or tap  scan the QR cord ► Tap **New Devices** ► Enter **Device Name** ► Enter **Device Name** ► Click the "<" sign in the upper right corner

4.6.4 Edit Operator and Viewer

The *Owner* account has management privileges and can edit and assign other accounts as *Operator* or *Viewer*. If an unauthorized account attempts to connect to monitor the device, the server will reject the connection request. By default, the account used to log in and bind the device is set as the *Owner* of the device, and it simultaneously has both *Operator* and *Viewer* permissions.

- **iOS and Android Operation** : KTool® APP ► Tap **Device Management** ► Swipe from right to left on the device name you wish to edit. ► Tap **Edit** . ► Enter the operator and Viewers email addresses (1-7) in sequence. ► Click the "<" sign in the upper right corner and return to the device list screen.

4.6.5 Unbinding

Once a PTS device is bound, it cannot be re-bound to another account unless the unbinding procedure is performed first. Unbinding can be executed either locally on the control unit or remotely via the Owner's mobile device.

- **Local Control Unit Operation** : In any status, press the Multi-function Rotary Knob ► **Other Settings** ► **Unbind**
- **iOS and Android Operation** : **KTool® APP** ► Tap **Device Management** ► Swipe from right to left on the device name you wish to edit. ► Tap **Delete** . ► Tap **Delete** . ► **Unbound**

4.6.6 Connect to the Control Unit

Once all the steps in Sections 4.6.1, 4.6.2, and 4.6.3 have been completed, the user can open the KTool® APP to connect to the control unit.

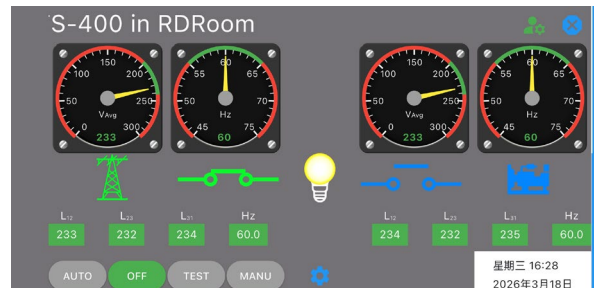

Select the device you want to connect to and tap the field to establish the connection.



: Represents *Operator* identity



: Represents *Viewer* identity

Operator Login Screen

Only when logged in with *Operator* identity, the operation buttons **AUTO** / **OFF** / **TEST** / **MANU** will appear at the bottom of the screen.

For other identities, the login screen will only display the current operation mode without operation buttons.

4.7 Remote Parameter Setting

Remote system parameter setting can only be executed under *Operator* identity and when in *OFF mode*. Otherwise, the options will automatically turn gray and parameter settings will not be allowed, but all parameter contents can still be viewed.



4.8 About this device

The *About This Device* section provides *PTS Device Name*, *Firmware Version*, *Serial Number* for reference by the user.

4.9 Software Update

Kutai will periodically provide updated versions of the control firmware for users to download and upgrade. Users can perform firmware updates in the following two ways:

1. Wi-Fi Network Connection:

When the controller message window displays the  symbol, turn the rotary knob to **OFF mode** ► **Function Menu** ► **Settings** ► **Firmware Update**, or connect a smart mobile device and tap the  symbol on the message bar at the top of the *KTool®* screen to execute the firmware update.

2. USB Connection:

Use a Type-C cable to connect to a Windows PC, visit the Download Center on Kutai website, and execute the firmware update.

⚠ WARNING When the Automatic Transfer Switch (ATS) is connected via remote monitoring, the ATS transfer operation and generator startup can be controlled remotely. Therefore, the generator must be placed in a fenced and protected area, and a clear permanent warning sign “Generator may start at any time” must be posted to alert personnel. Failure to do so may result in personal injury or death.

NOTICE When using the remote monitoring function, it is recommended to power the control unit with a battery supply. Otherwise, if both Utility Power and Generator Power are disconnected at the same time, remote communication will be interrupted.

NOTICE To ensure that the control unit firmware and the *KTool*® application remain in optimal operating condition, users should periodically connect the control unit with the mobile device to check for available updates.

4.10 Remote Monitoring Service Fee

When the control unit is bound for the first time and connected through the KTool® APP, the system will automatically activate a **60-day free trial period** for remote monitoring.

After the trial period ends, if the user still requires remote monitoring connection, the company will charge an annual service fee to maintain the connection function.

The system will send a push notification 7 days prior to service expiration as a reminder for payment.

Annual Fee Plan <https://www.kutai.com.tw//servicefee>

4.11 Payment Methods

4.11.1 Payment on KUTAI Website

KUTAI website ► *Member Center* ► Enter Member Account / Password ► *Service Payment* ► Click or fill in the *Serial Number* ► Click *Read and agree to terms of service* ► Click *SUBMIT* ► Select *Country* ► Enter *Unified Business Number* (if applicable) ► Click *Confirm Payment* ► Link to the third-party payment platform ► Select the payment method ► Complete the online payment operation

SECTION 5 : OPTIONAL ACCESSORIES

1. Terminal Cover Set (C400-3/C400-4)
2. Extended Operation Display Module ([ATSC403B](#)) (with two Type-C cables, optional for 1M or 2M length)
3. Wi-Fi Antenna with Base (ANK92) ◦
4. Current Transducer & Communication Module (CTM-3K) (with optional cables 0.5M or 1M length)
5. Interface for KCU Communication Module (KCU-IF) (with optional cables 0.5M or 1M length)
 - 5-1 Modbus-RTU Communication Module ([KCU-05](#)).
 - 5.2 SNMP Communication Module (KCU-06).
 - 5.3 Modbus TCP/IP Communication Module ([KCU-07](#)).
 - 5.4 Ethernet (Dynamic IP) Communication Module ([KCU-31](#))

※ Refer to product User Manual for detail specification and installation instructions.